



# INSTALLATION GUIDE

## RESYSTA WALL CLADDING (HF CLIP)



### 1. Introduction

#### 1.1 Material Components

#### 1.2 Basics

#### 1.3 Scope of Profiles

### 2. Installation – Procedure

#### Sec.1 Batten Substructure

#### Sec.2 Trim and Accessory Option

#### Sec.3 Horizontal Wall Cladding

#### Application

#### Sec.4 Multi-Board Horizontal Wall

#### Cladding Application

#### Sec.5 Vertical Wall Cladding

#### Application

#### Sec.6 Multi-Board Vertical Wall

#### Cladding Applications

#### Sec.7 Air Barrier Requirements

#### Sec.8 Finishing Option – Trims and

#### Hollow Cap

#### Sec.9 Stain and Sealant System

### 3. Safety Warning

# 1. Introduction

Resysta is an extremely durable, timber look-alike, building material. It is resistant to damage from the sun, rain, frost and even salt water. Unlike wood, it requires minimal maintenance and is highly resistant to pests, mold and cracks. Unlike other composite materials, it closely resembles the look and feel of natural wood, with a smooth surface finish. Resysta meets most of the future environmentally sustainable material requirements concerning recycled and fully recyclable materials. Resysta is used for its architectural aesthetic, and not for structural support.

## 1.1 Material Components

A combination of these three basic raw materials make up the simple components that create Resysta. This innovative material offers designers and architects new creative horizons to utilize its compelling and unique appearance.



Approx. 60% RICE HUSK + Approx. 22% COMMON SALT + Approx. 18% MINERAL OIL



= RESYSTA PRODUCT

## 1.2 Basics

### OVERVIEW OF PARTS

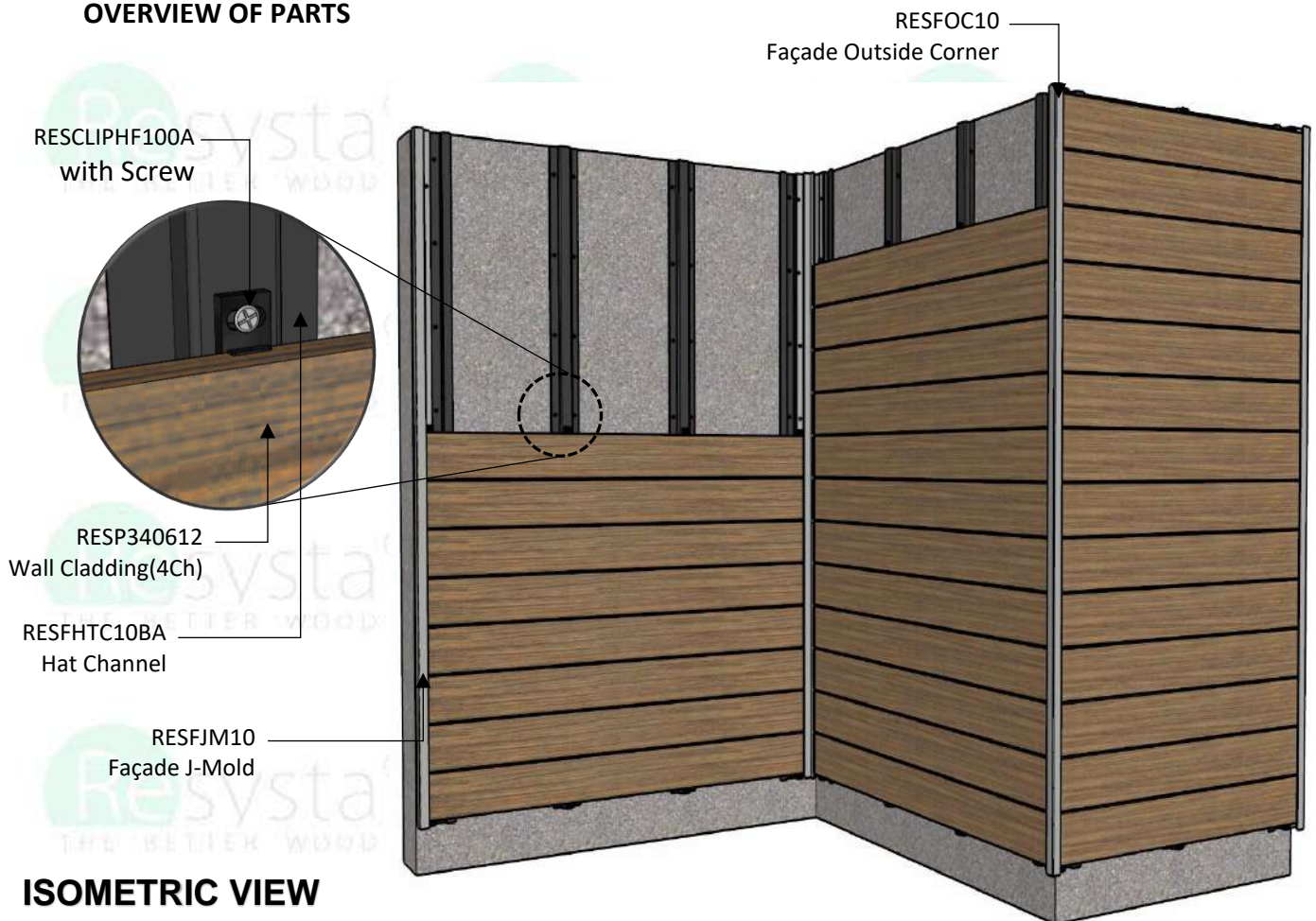

### ISOMETRIC VIEW BASIC PARTS OF U-BRACKET

### 1.3 Scope of Profiles

NO.	PRODUCT NAME AND SPECIFICATION	ISOMETRIC VIEW	FRONT VIEW
1	<b>RESP340812</b> 13/16" x 7 7/8" Cladding (7Ch)		
2	<b>RESP340612</b> 13/16" x 5 1/2" Cladding (4Ch)		
3	<b>RESP1231212</b> 5/8" x 3 1/2" Cladding (3Ch)		
4	<b>RESP3423412</b> 13/16" x 2 3/4" Cladding (2Ch)		
5	<b>RESP1223412</b> 5/8" x 2 3/4" Cladding (3Ch)		
6	<b>RESFOC10</b> Façade Outside Corner A=1 1/8" B=1"		
7	<b>RESFJM10</b> Façade J Mold A=1 1/8" B=1"		
8	<b>RESFHM10</b> Façade H Mold A=1 1/8" B=1"		
9	<b>RESFHTC10BA</b> Façade Hat Channel Black Anodized 1/2" x 1 1/2" (12mm x 38mm)		
10	<b>RESCLIPHF100W</b> Façade Clip for Wood Batten  <b>RESCLIPHF100A</b> Façade Clip for Aluminum Hat Channel		

**Table 1.1 "Resysta Profiles"**

Table above shows products commonly used for wall cladding. To view a complete list of products, please refer to our Resysta brochure or visit our web site [www.resystausa.com](http://www.resystausa.com)

**NOTE:**

Proper planning of the wall cladding layout is essential for ease of installation of wall cladding boards and wall cladding components. Thoroughly read the following wall cladding assembly instructions and obtain all necessary building permits prior to starting your installation. Decide finishing and trimming options prior to starting the project to ensure wall cladding finishing detail is uniform for all sides of the building. Installation is the sole responsibility of the installer. Resysta Company assumes no responsibility whatsoever with respect to the installation. The information contained herein is provided for guidance purposes only and should not be relied upon as any absolute representation by Resysta.

**IMPORTANT: Five Major Bullet Points You Must Follow to Meet Resysta Warranty Guidelines.**

- Screw Placement
- Room for Expansion and Contraction
- Hard Fastening of each Plank
- Bottom to Top Ventilation
- Span over 6'' between support, 3 Hat Channels are required

**Safety Tips:**

1. Always check for power, gas, and water lines before installing.
2. Always wear safety glasses when operating power equipment.

**Assembly Tips:**

1. Battens should be flat and level to each other. Wall cladding will follow the contour of the wall.
2. Resysta wall cladding is not a rain screen or water proof system. Resysta wall cladding is a water shed system.
3. Proper wall preparation according to local building codes and wall covering manufacture's recommendations should be adhered to. This includes but is not limited to flashing all openings.
4. All holes should be predrilled and installation holes should be slotted.
5. Only use construction fastening material and hardware suitable for outdoor use (e.g. stainless steel screws).
6. Always consider the linear expansion of Resysta, which is dependent on the temperature but not the air humidity. See Table 1.3 "Resysta Expansion" for more information.
7. Cut-off pieces and/or abrasive dust must be disposed of separately. Please comply with regulations of your competent waste management. You may under no circumstances burn Resysta material.
8. Cutting to length should be carried out at consistent material temperature. Therefore, the material should be stored in the shade or in areas where it is not exposed to direct sunlight. The material can warm up considerably in the sun, leading to an increased change in length. In the case of more distinct fluctuations in material temperature, cutting to length may have to be adapted accordingly.
9. Please store Resysta products flat on level surface.

## Code Compliant Joist Spacing

Part Number	Part Description	Batten Span (in)	Minimum Steel Gage Size
RESP3423412	Wall Cladding (2 Channel) 13/16" x 2 3/4" (20mm x 70mm)	16	20
RESP1223412	Wall Cladding (2 Channel) 5/8" x 2 3/4" (15mm x 70mm)	16	20
RESP1231212	Wall Cladding (3 Channel) 5/8" x 3 1/2" (15mm x 90mm)	16	15
RESP340612	Wall Cladding (4 Channel) 13/16" x 5 1/2" (20mm x 140mm)	16	20
RESP340812	Wall Cladding (7 Channel) 13/16" x 7 1/2" (20mm x 140mm)	16	20

**Table 1.2 "Batten Spacing Requirements"**

**Recommendation for Batten Spacing** – If the wall cladding is being installed in a hot southern location and will be exposed to direct sunlight for the majority of each day and/or the wall cladding will be stained a dark color, the batten spacing is suggested be reduced to 8" or 12" center-to-center for all wall cladding profiles.

## Expansion / Contraction of Wall Cladding

Resysta Expansion – Contraction Guide	
Profile Length	12 ft
Expansion / Contraction amount (approx.. 0.3% over 90 oF variation in temperature)	7/16" (0.432")

**Table 1.3 "Expansion – Contraction"** – Average expected expansion – contraction (this can vary based on geographical region).

Resysta Wall Cladding Board Gap Guide					
Temperature at Installation	Trim Gap of Wall cladding Boards				H-Channel Gap
	Below 30 oF	60 oF	90 oF	120 oF	
Amount for Wall cladding Profile – Length of 12 ft.	7/16"	5/16"	3/16"	0"	1/4"

**Table 1.4 "Resysta Expansion"** – Ensure a steady material temperature when cutting the boards to size, i.e. the cutting has to be done under constant conditions, e.g. inside or in shade.

Always consider linear expansion of Resysta profiles during the installation of wall cladding products. If temperatures fluctuate during the installation, the gaps placed between the ends of the boards and a corner, window, or door must change with the temperature. Use the guide above to gap boards during installation.

**Expansion – Contraction Tips:**

1) Control Piece – at the start of the day cut a length of board that is desired to be installed and keep this board in the same area as the cutting and storage of the remaining boards. This board will be a “Control Piece” to reference when cutting other boards to be installed. Throughout the day the “Control Piece” can be referenced and the saw cuts adjusted accordingly as the boards expand and/or contract. Heat from the sun will cause Resysta boards to expand so if the material is stored in the shade keep the “Control Piece” in the shade as well.

**Example:** If 12ft boards are being installed put aside one 12ft board at the start of the day. Reference these boards throughout the day and adjust the cutting of the other boards to match

2) Control Gap – at the start of the installation place the wall cladding gap according to Table 1.4 and mark the first gap made. This gap will be a “Control Gap” to reference when gapping the remaining boards to be installed. Throughout the installation reference back to this “Control Gap” to match the other gaps being installed. This will ensure that all the gaps installed are the same.

**2. Installation - Procedure**

**SECTION 1 – Batten Substructure**

**General Notes on Batten Substructure**

Resysta wall cladding boards can be installed in horizontal or vertical applications and the batten substructure should be planned to accommodate how the wall cladding boards will be installed.

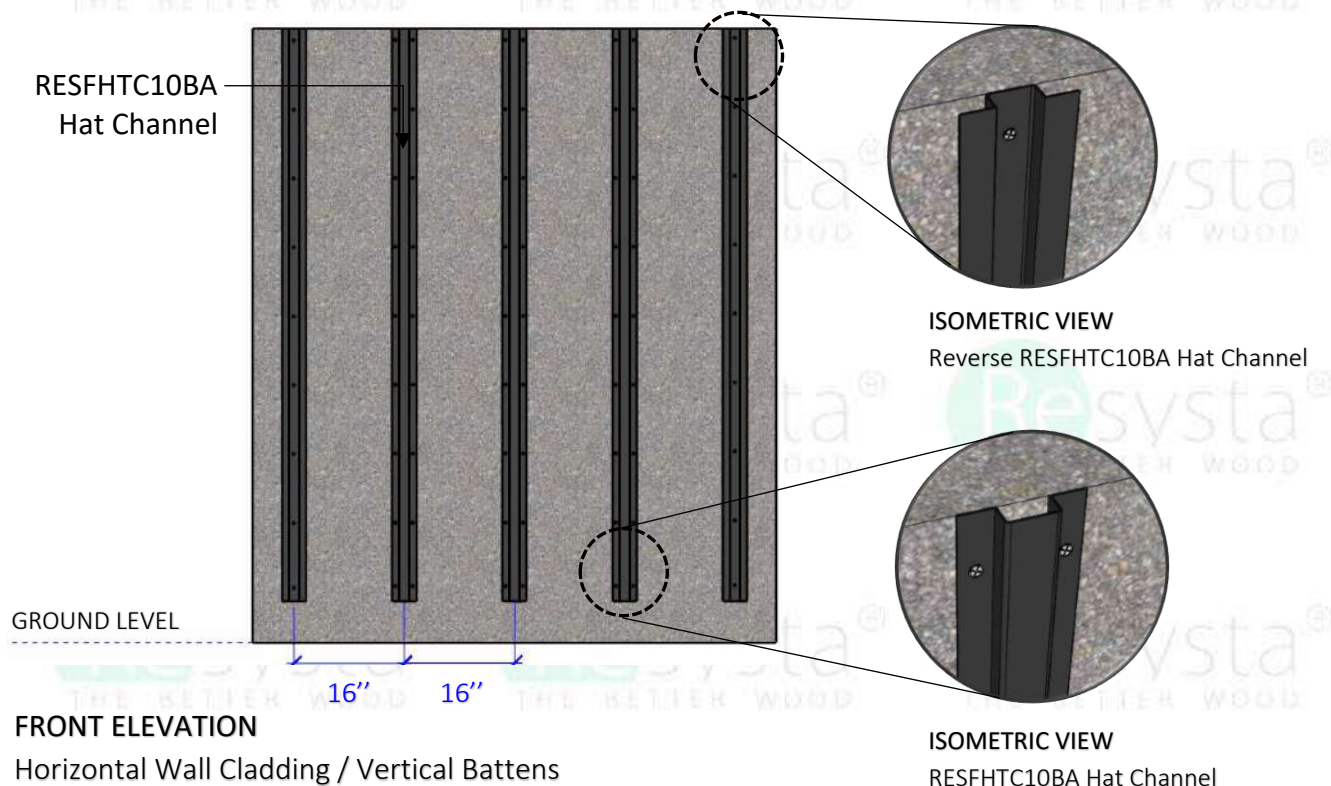

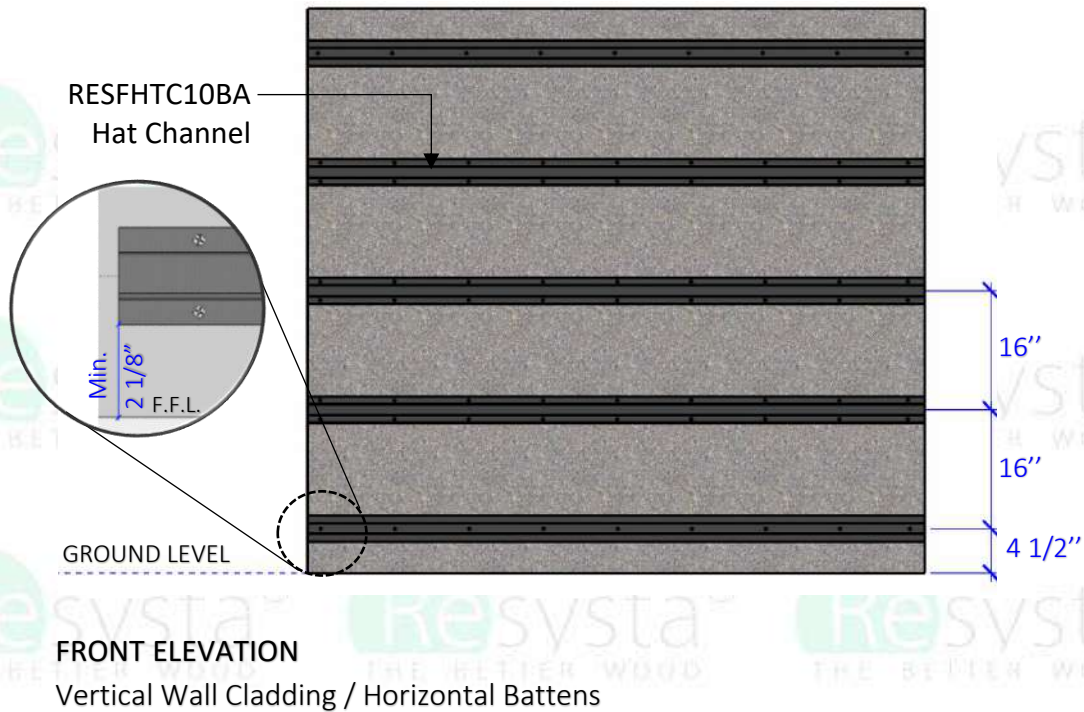

Resysta wall cladding boards require a minimum of 3" from the ground to the start of the wall cladding board in both horizontal and vertical installations. Plan the batten substructure and wall assembly accordingly to accommodate wall cladding installation while adhering with local building code requirements.

### Wood Batten Substructure

Install the battens and secure to the frame substructure in compliance with local building codes. Ensure that the installed battens do not exceed the "Batten Spacing Requirements" of Table 1.2. On walls where two wall cladding boards will be used end-to-end, a minimum of two battens must be used to accommodate the fastening of the wall cladding boards and any trim pieces desired to the batten substructure where the boards meet. Prior to installing the Resysta wall cladding boards, ensure that the batten installation provides a minimum 1/2" air gap behind the wall cladding boards and there is sufficient support for all wall cladding boards and trim accessories. This is often achieved through the installation of battens with a minimum thickness of 1/2".

Battens should be installed on top of a code compliant sheathing with fasteners and fastener spacing sufficient to accommodate all loads imposed upon it by the Resysta wall cladding board, trim components, and any other accessories attached to the battens. Resysta wall cladding boards must be attached to wood battens with Clips and #8 x 1-1/4" stainless steel fasteners taking care to not penetrate the weather barrier. If the weather barrier is going to be penetrated reference the weather barrier manufacturer's recommendations.

### Metal Batten Substructure

Install the battens and secure to the frame substructure in compliance with local building codes. Ensure that the installed battens do not exceed the "Batten Spacing Requirements" of Table 1.2. On walls where two wall cladding boards will be used end-to-end, a minimum of two battens must be used to accommodate the fastening of the wall cladding boards and any trim pieces desired to the batten substructure where the boards meet. Prior to installing the Resysta wall cladding boards, ensure that the batten installation provides a minimum 1/2" air gap behind the wall cladding boards and

there is sufficient support for all wall cladding boards and trim accessories. This is often achieved through the installation of battens with a minimum thickness of ½”.

Battens should be installed on top of a code compliant sheathing with fasteners and fastener spacing sufficient to accommodate all loads imposed upon it by the Resysta wall cladding board, trim components, and any other accessories attached to the battens. Resysta wall cladding boards must be attached to wood battens with Clips and #8 x ½” stainless steel fasteners taking care to not penetrate the weather barrier. If the weather barrier is going to be penetrated reference the weather barrier manufacture’s recommendations.

**NOTE: It is highly recommended to use the Hat Channel (Black) (RESFHTC10BA) for the installation of the Resysta Wall Cladding.**

## **SECTION 2 – Trim and Accessory Options**

Aluminum Wall cladding Trim systems made for Resysta wall cladding boards are recommended for covering the ends and gaps of wall cladding boards. Suggested supply includes, but is not limited to: Outside Corner Trim (RESFOC10), H-Channel Trim (RESFHM10), J-Mold Trim (RESFJM10), (to cover wall gaps), Hat Channel Black (battens to be used for substructure). Aluminum Wall Cladding Trims are standard aluminum alloy 6063 T5 and have a .050” nominal wall thickness. Aluminum Wall Cladding Trims come in 10’ lengths and shall have a standard Mill Finish for field priming and painting unless otherwise specified.

### **Aluminum Wall Cladding Trim – General Installation Guidelines**

Aluminum Wall Cladding Trim must be cut with a 150 tooth carbide-tip blade for nonferrous metal. Blade Lubricant must be applied to the blade before each cut and the lubricant should be cleaned from the trim prior to installation. None of Wall Cladding Trim should be installed horizontally unless weep holes are drilled at 8” intervals to allow for moisture to escape from behind the face flange.

### **Aluminum Wall Cladding Trim – Wood Batten Installation Guidelines**

Aluminum Wall Cladding Trim must be pre-punched or drilled to receive the #8 x 5/8” wood screw for attaching them to wood furring strips. Trim should be fastened 16” on center for either horizontal or vertical installations. If the batten substructure spacing is reduced for the Wall Cladding boards the trim should be fastened at the same interval as the Wall Cladding. Be aware of fastener placement for the Wall Cladding trims so as to not hinder the installation of the Resysta Wall Cladding boards.

Depending on the type of wood battens used there is the possibility for the aluminum trim to go through the aluminum electrolysis effect. If this occurs, the aluminum trim could start to deteriorate. This is an extremely rare event that requires the correct conditions. However, if this is a concern it is recommended that a piece of felt be installed between the wood battens and the aluminum trim.

### **Aluminum Wall Cladding Trim – Metal Batten Installation Guidelines**

When using metal battens, either steel or aluminum, it is recommended to use a #8 x 5/8” self-tapping fastener which can be driven through the aluminum wall cladding trim and into the metal batten. Trim should be fastened 16” on center for either horizontal or vertical installations. If the batten substructure spacing is reduced for the wall cladding boards the trim should be fastened at the same interval as the wall cladding. Be aware of fastener placement for the wall cladding trim so as to not hinder the installation of the Resysta wall cladding boards.

## SECTION 3 – Horizontal Wall Cladding Applications

**NOTE:** *This installation is for the 4 Channel Hollow Wall Cladding profile, but the same rules apply to all the Resysta Wall Cladding boards.*

### STEP 3.1

Pre apply all finishing trim accessories such as trim around corners, windows, and doors according to the pre plan layout and following the manufacture’s recommendations. Ensure that all trim is level and square. Battens should be installed vertically.

### STEP 3.2

Attach HF Clips with the integrated assembly stop to the back side of the wall cladding board with 2 #8 x ½” SMS screws. Clips need to be installed 16” apart to make sure they line up with the battens.



**REAR ISOMETRIC VIEW**  
Horizontal Wall Cladding  
Details

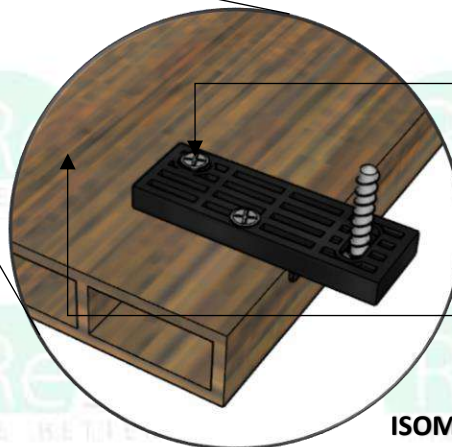

RESCLIPHF100A  
with Screws

RESP340612  
Wall Cladding

**ISOMETRIC VIEW**

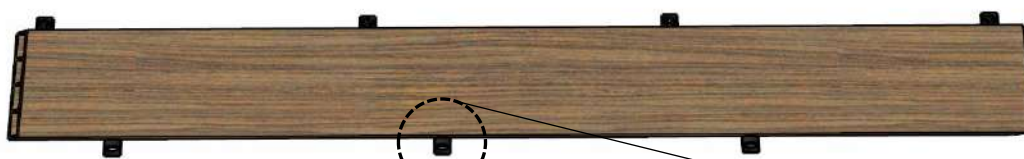

**FRONT ISOMETRIC VIEW**  
Horizontal Wall Cladding  
Details



RESCLIPHF100A  
with Screws

RESP340612  
Wall Cladding

**ISOMETRIC VIEW**

**Note:**

*Make sure the first clip is attached within 1” from the end of the wall cladding board.*

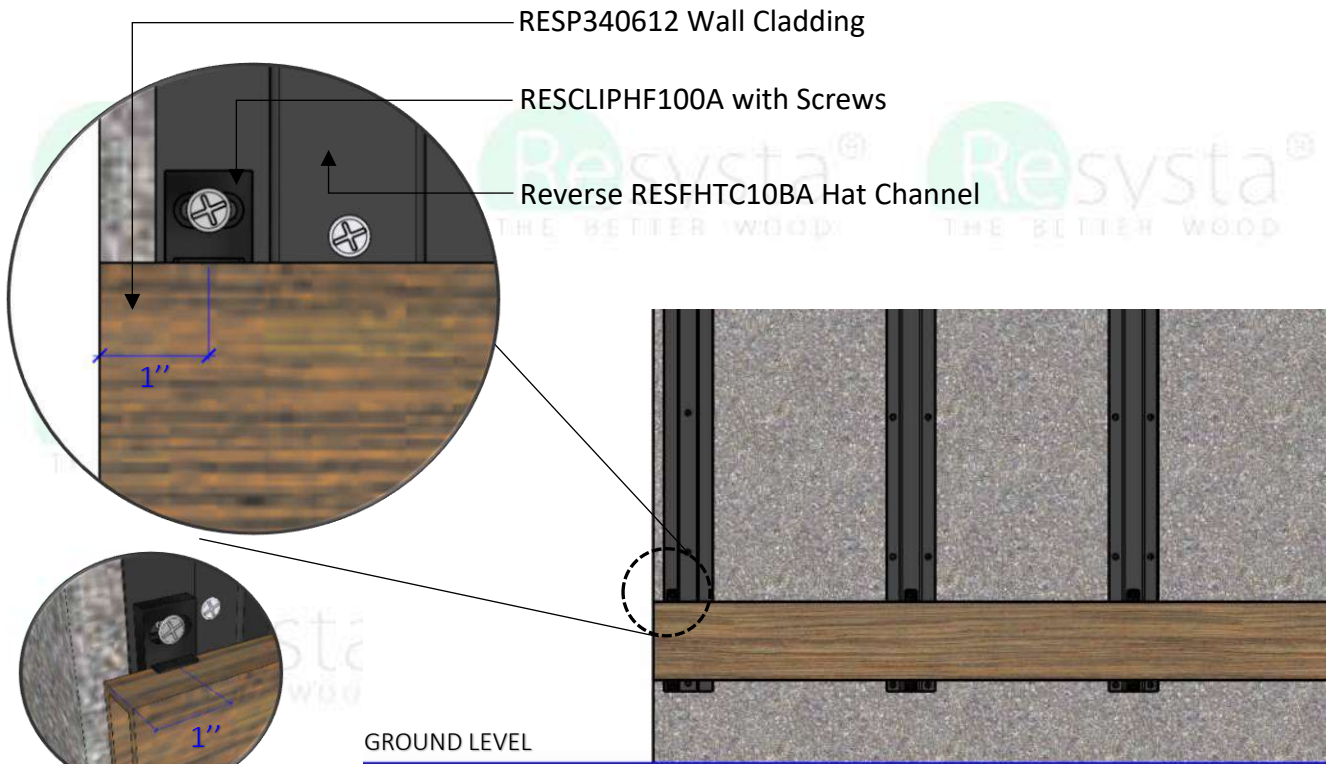

ISOMETRIC  
VIEW

FRONT ELEVATION  
Horizontal Wall Cladding Details

**Note:**

Each HF Clip requires 3 screws. Two are #8 x 1/2" SMS screws to attach the Clip to the Resysta Wall Cladding board and one is to attach the wall cladding board with the clip to the battens. Depending on the type of the substructure Resysta offers two types of screws: #8 x 1/2" TEK Screw for the Aluminum Substructure (Hat Channel) and #8 x 1 1/4" for the wooden substructure.

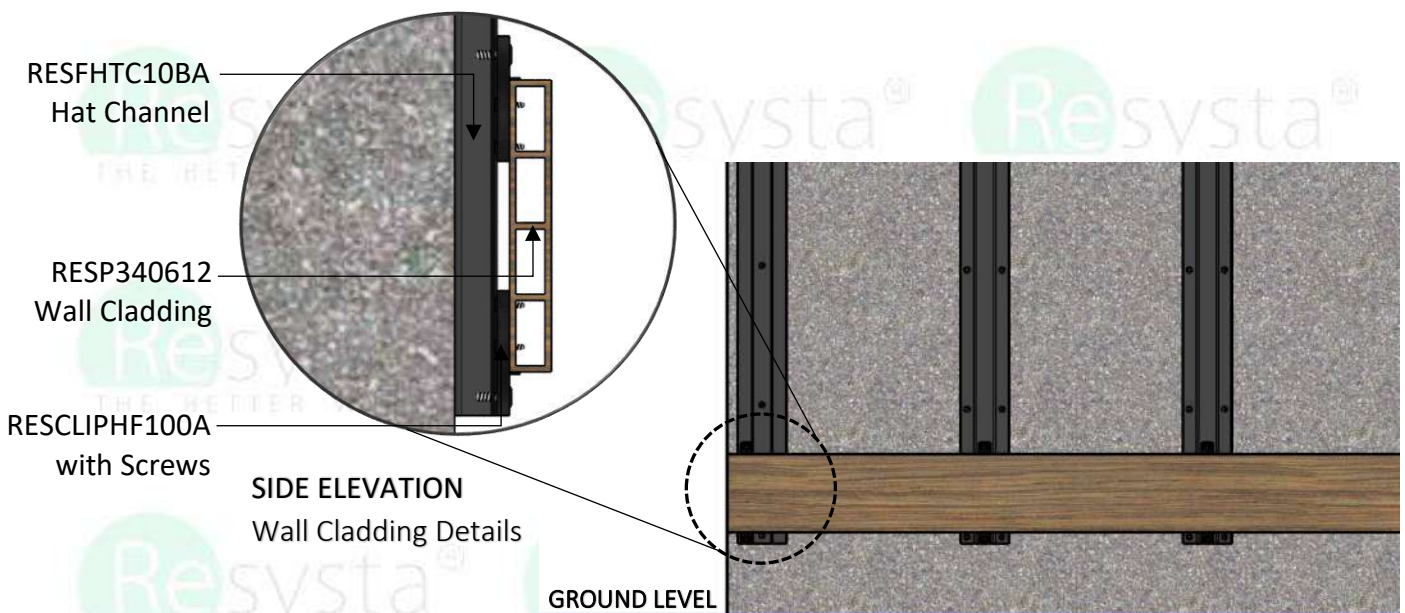

SIDE ELEVATION  
Wall Cladding Details

GROUND LEVEL

FRONT ELEVATION  
Horizontal Wall Cladding Details

**STEP 3.3**

Install starter wall cladding board 3" from the Ground. Use the provided screw to attach the wall cladding board with the clips to the battens.

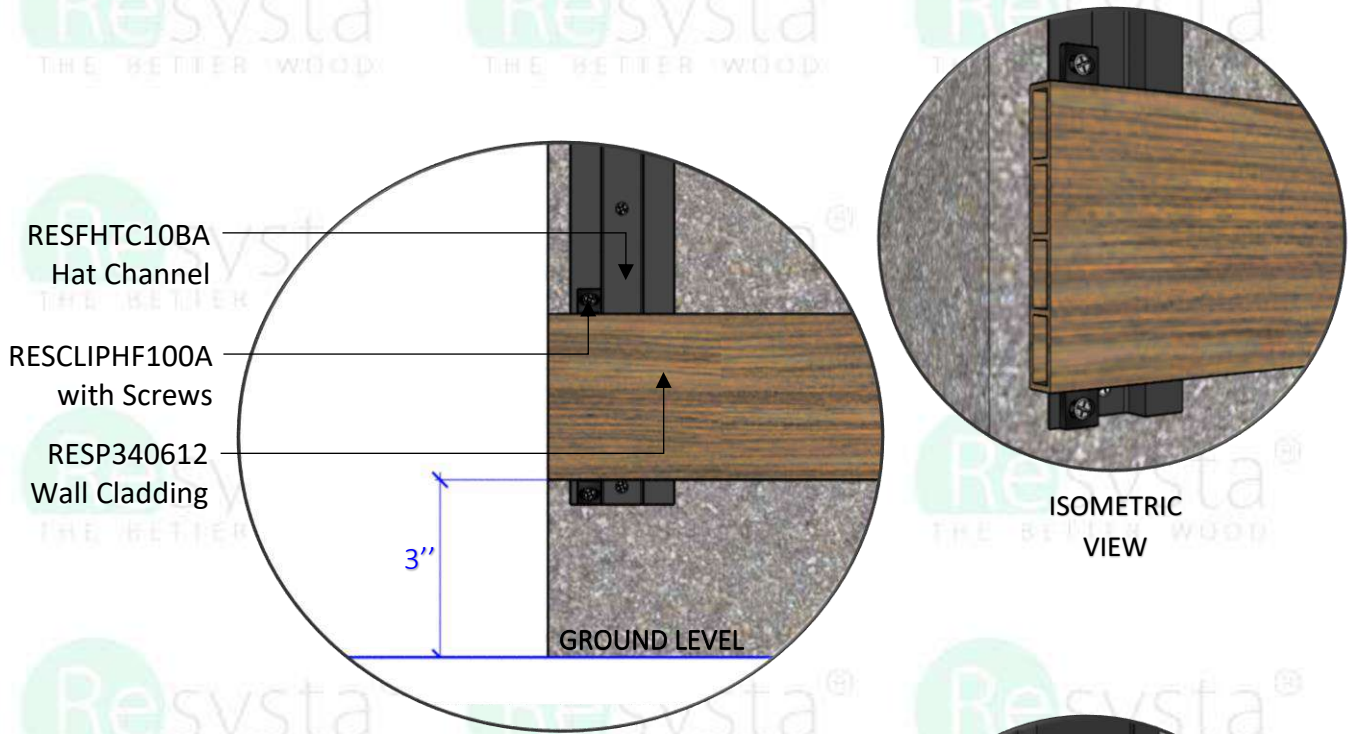

- RESFHTC10BA  
Hat Channel
- RESCLIPHF100A  
with Screws
- RESP340612  
Wall Cladding

**FRONT ELEVATION**  
Horizontal Wall Cladding Details



**ISOMETRIC VIEW**

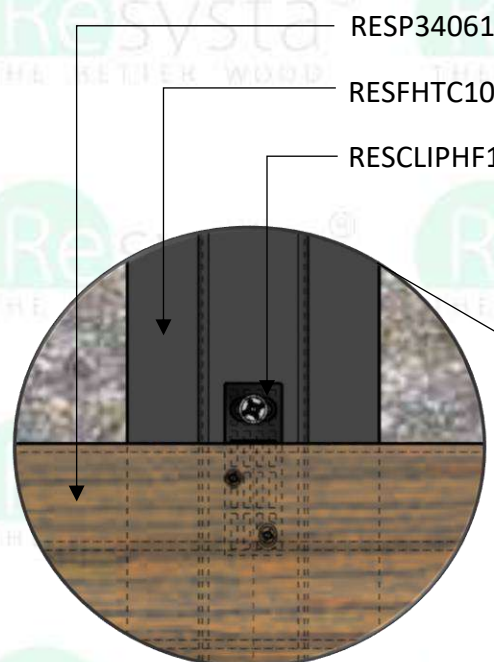

**FRONT ELEVATION**

- RESP340612 Wall Cladding
- RESFHTC10BA Hat Channel
- RESCLIPHF100A with Screws

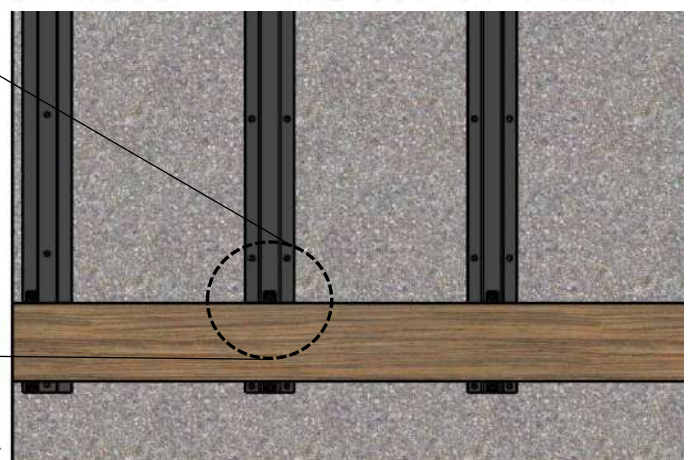

GROUND LEVEL

**FRONT ELEVATION**  
Horizontal Wall Cladding Details

**STEP 3.4**

Attach HF Clips to the top and the bottom of the 2<sup>nd</sup> board. Make sure the clips on the top and the bottom of the 2<sup>nd</sup> board don't line up with the clips on the starter wall cladding board, otherwise the boards will not line up correctly.

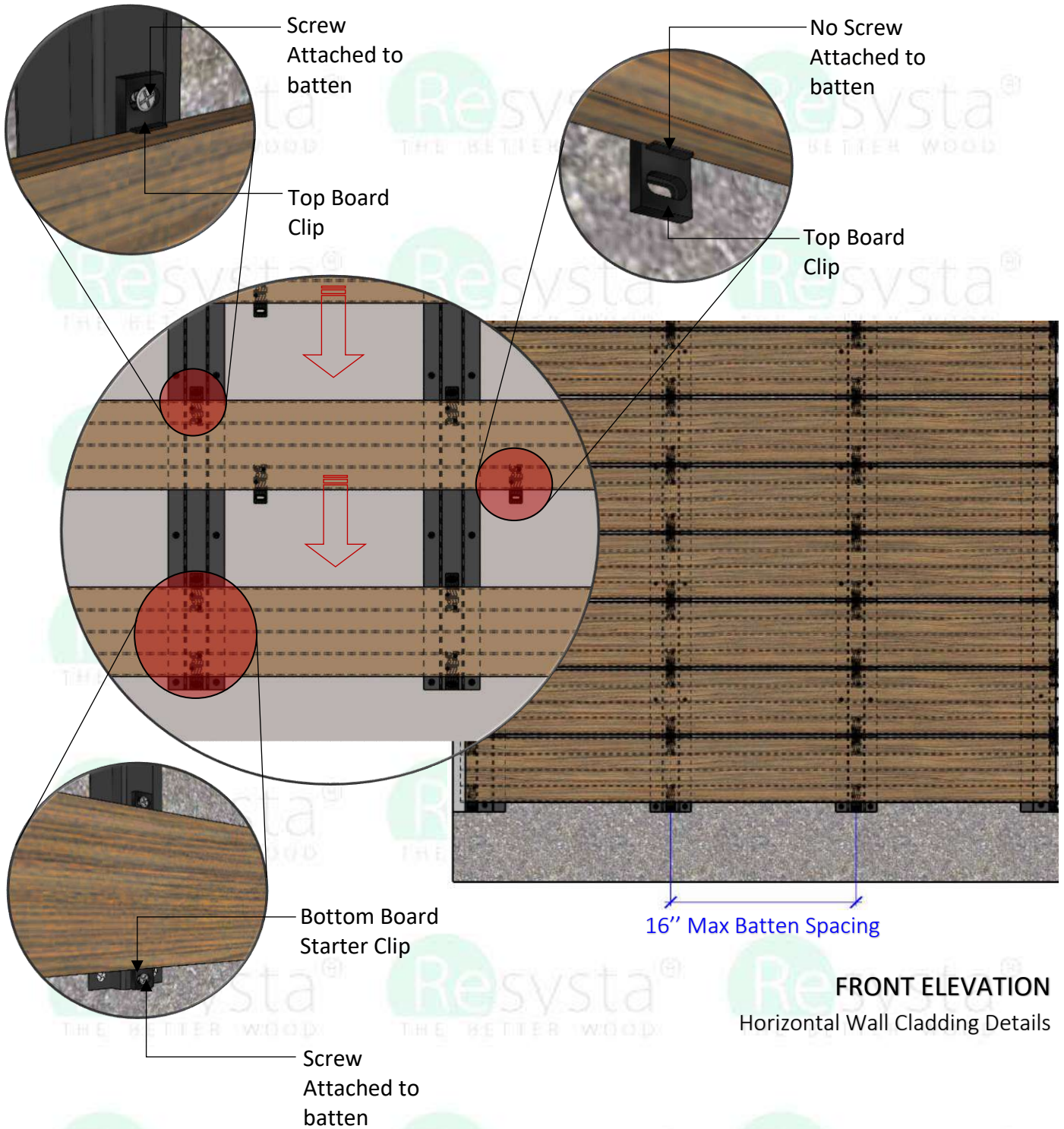

**Note:**

Bottom Clips do not require 3<sup>rd</sup> screw for the attachment to the battens.

**STEP 3.5**

Slide in the bottom clips on the 2<sup>nd</sup> wall cladding board into the gap behind the starter wall cladding board and fasten the top clips on the wall cladding board to the battens.

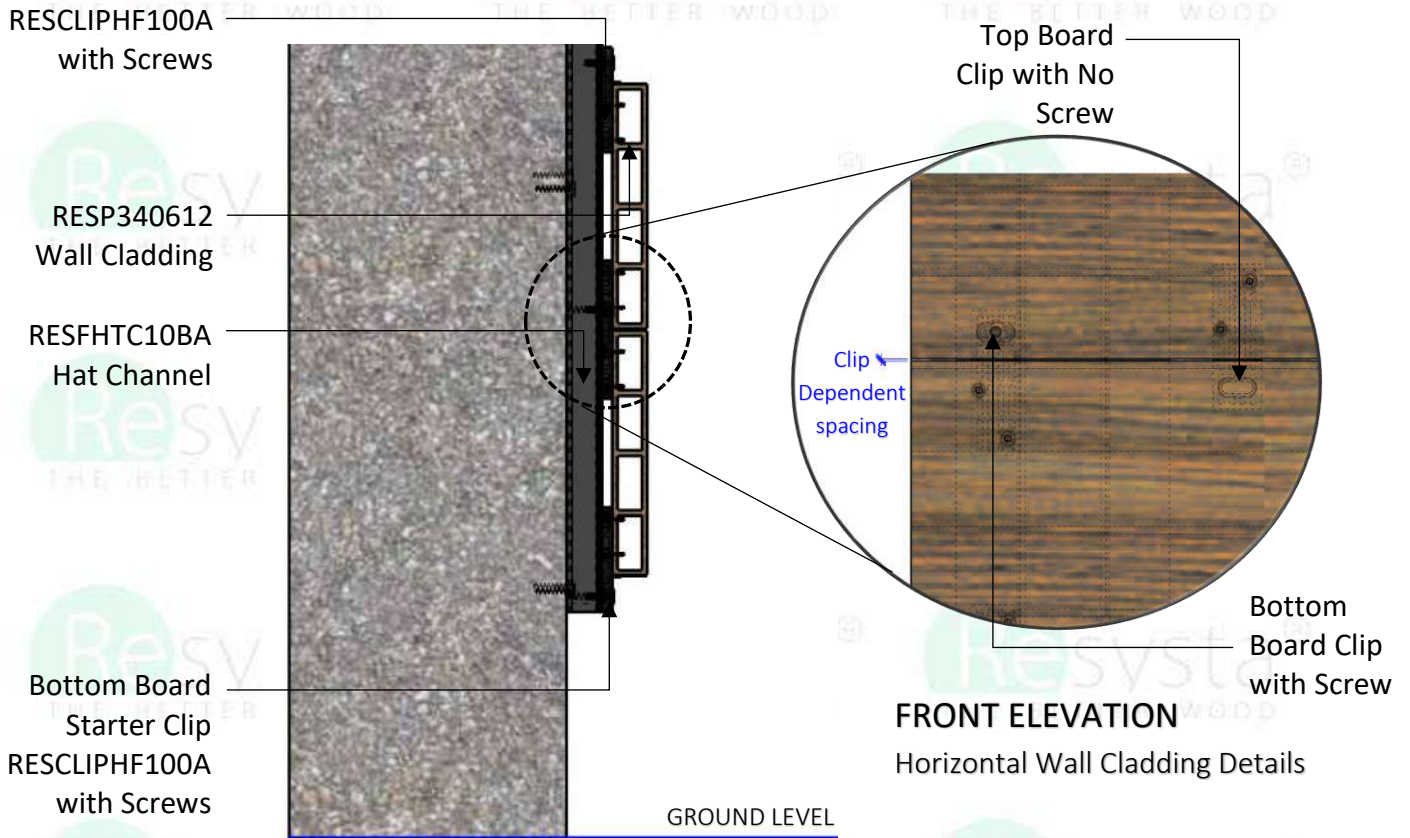

**SIDE ELEVATION**  
Horizontal Wall Cladding Details

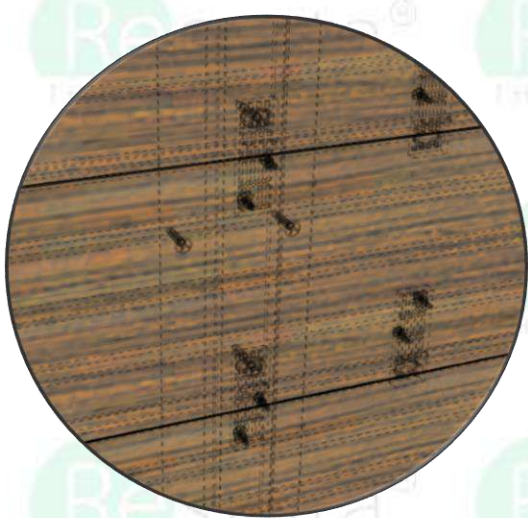

**FRONT ISOMETRIC VIEW**  
Horizontal Wall Cladding Details

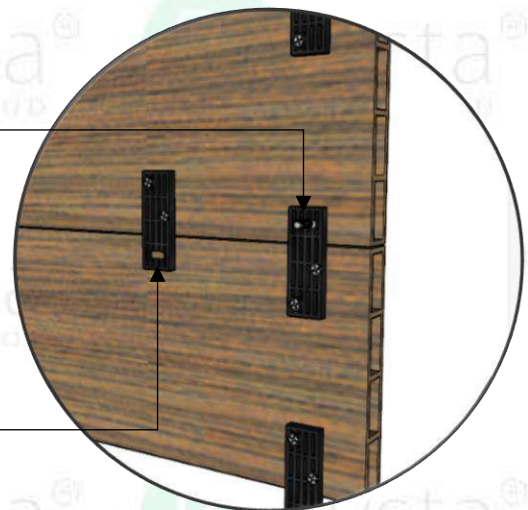

**REAR ISOMETRIC VIEW**  
Horizontal Wall Cladding Details

### STEP 3.6

Continue installing cladding boards as outlined in Section 3. Rip last siding board into size with Top board clip.

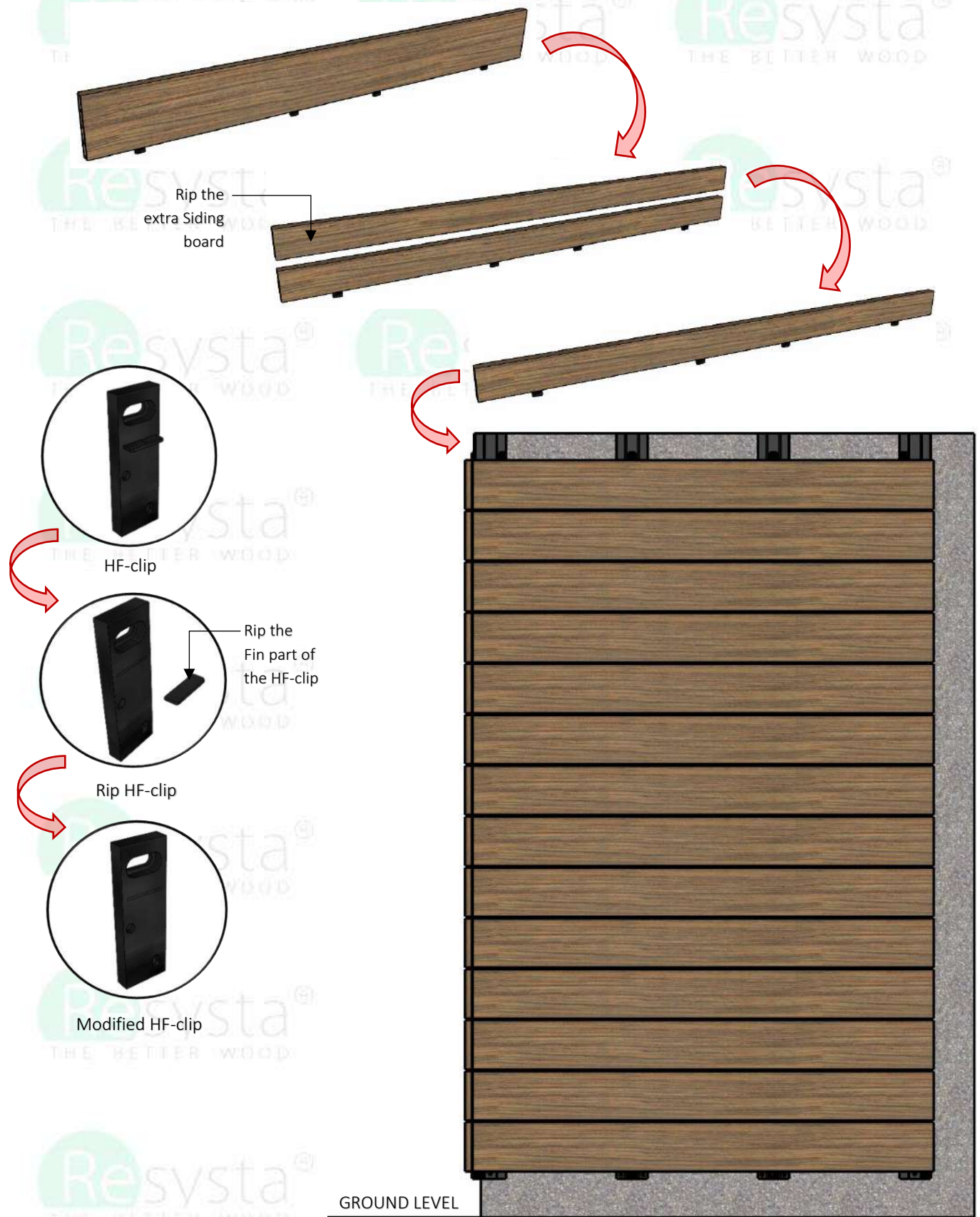

**FRONT ELEVATION**  
Horizontal Wall Cladding Details

### STEP 3.7

Provide a pre drilled hole in front and back face of the last cladding board as per the diagram. Install the modified HF-clip in every Hat Channel where the holes are located.



Modified front board with pre drilled hole

Modified back board with pre drilled hole

Modified HF-clip

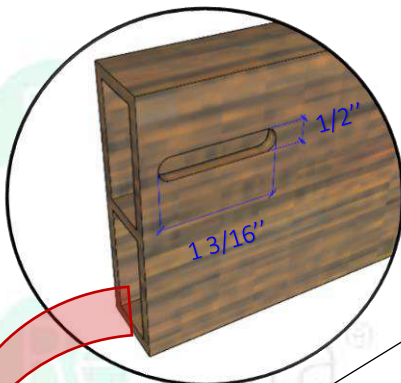

Rear View pre drilled hole

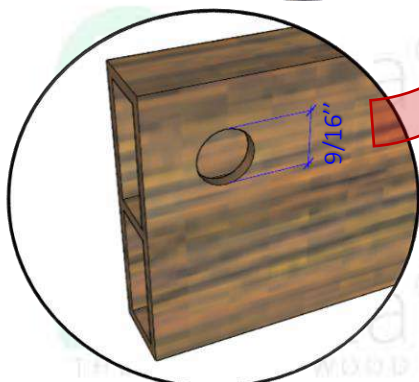
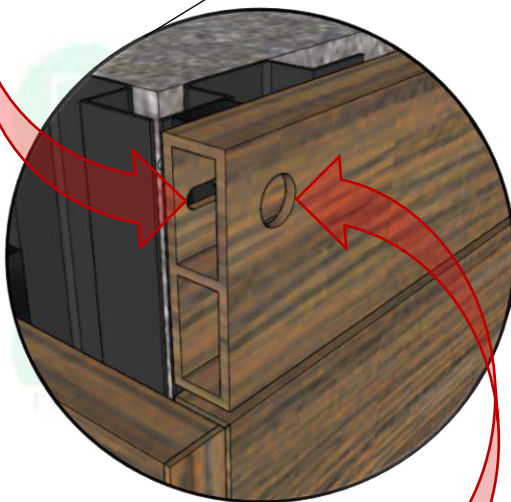

Front View pre drilled hole

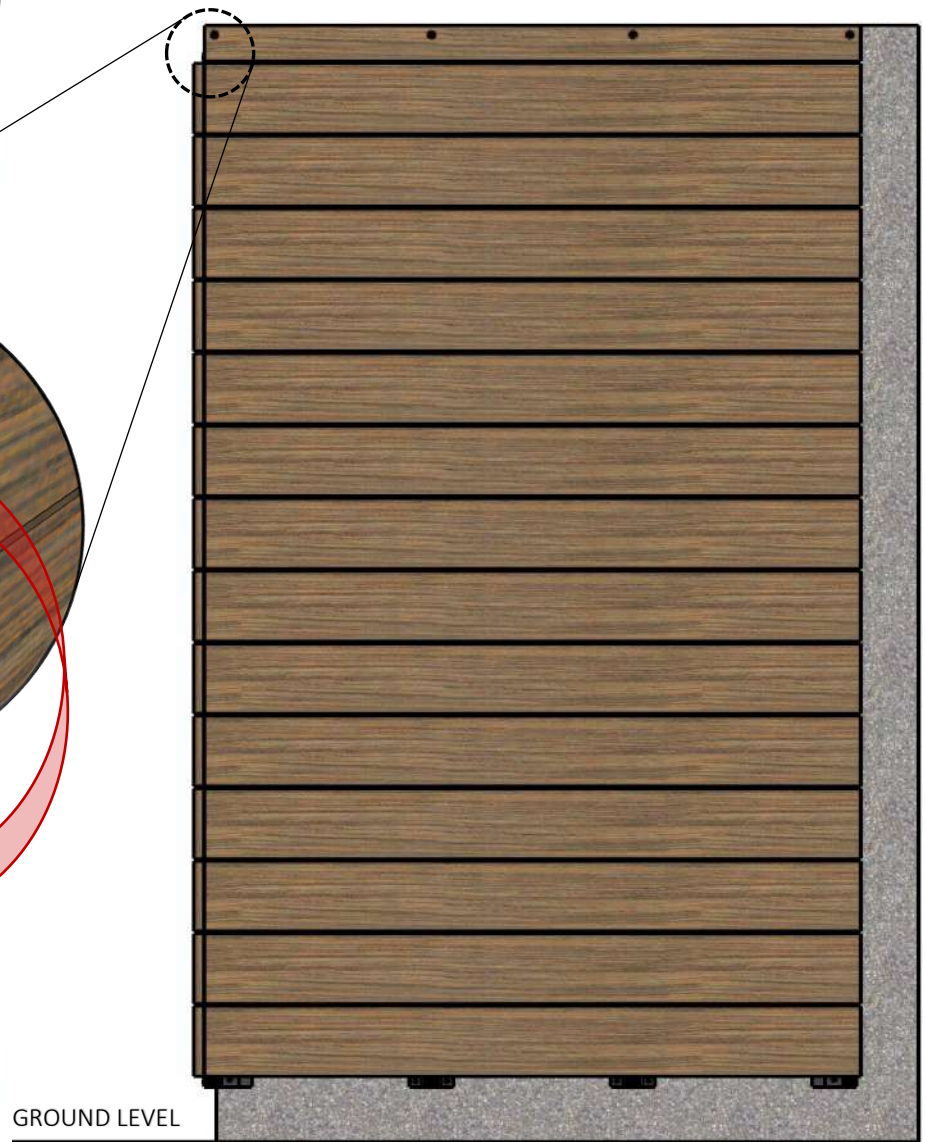

FRONT ELEVATION

Horizontal Wall Cladding Details

### STEP 3.8

Screw the cladding board thru the pre drilled hole on the Hat Channel and stick a 1" diameter veneer cap on every hole.

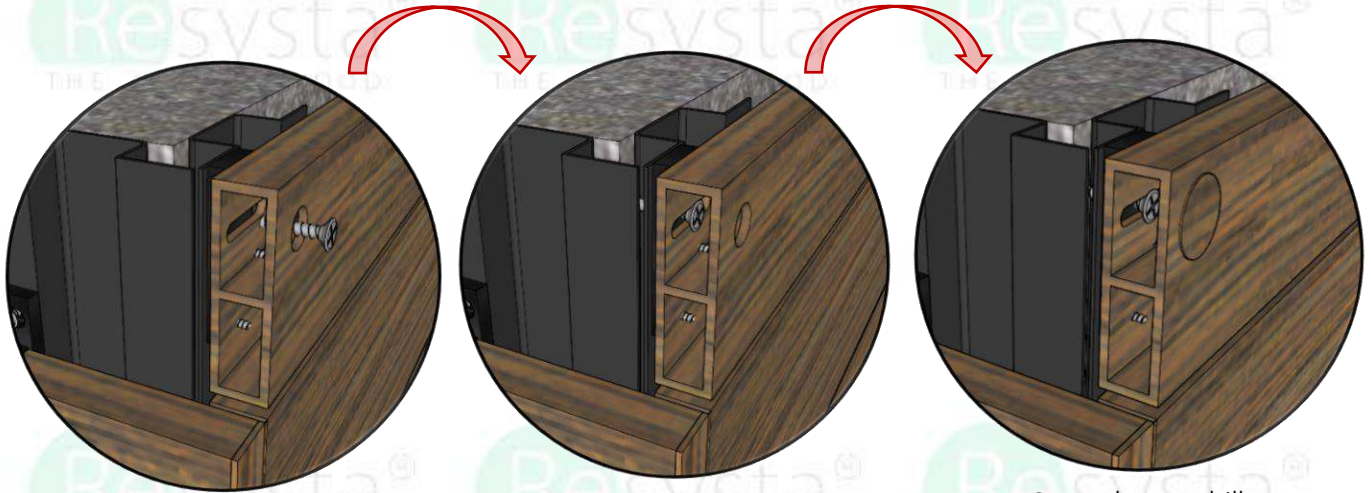

Insert the screw thru the hole

Screw the board thru the hole

Cover the pre-drill hole

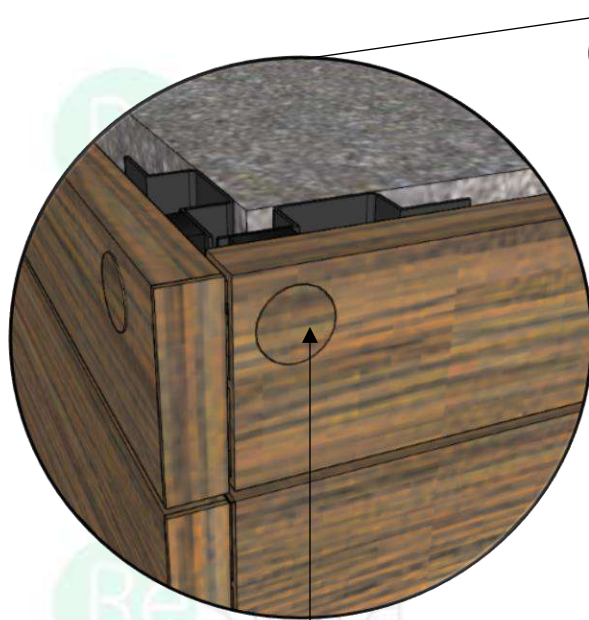

1" diameter veneer cap on every hole

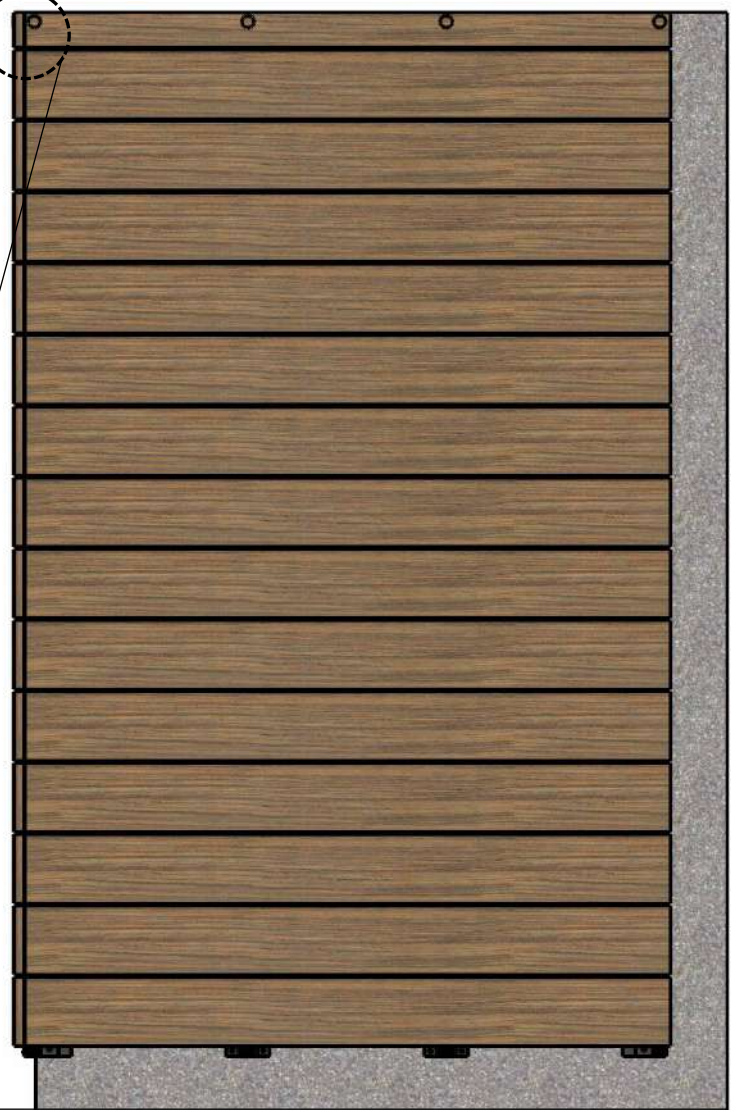

GROUND LEVEL

**FRONT ELEVATION**  
Horizontal Wall Cladding Details

**SECTION 4 – Multi-Board Horizontal Wall Cladding Applications**

**2 Board Wide Installation without the H-Channel Trim (24ft max width)**

**STEP 4.1.1**

Ensure that two battens have been installed where boards are to be installed end to end.

**STEP 4.1.2**

Follow Steps 3.1, 3.2, and 3.3 from Section 3 to install finishing trim and fasten the starter wall cladding board.

**STEP 4.1.3**

Install the 2<sup>nd</sup> starter wall cladding board next to the 1<sup>st</sup> one with the consideration for the proper gapping.

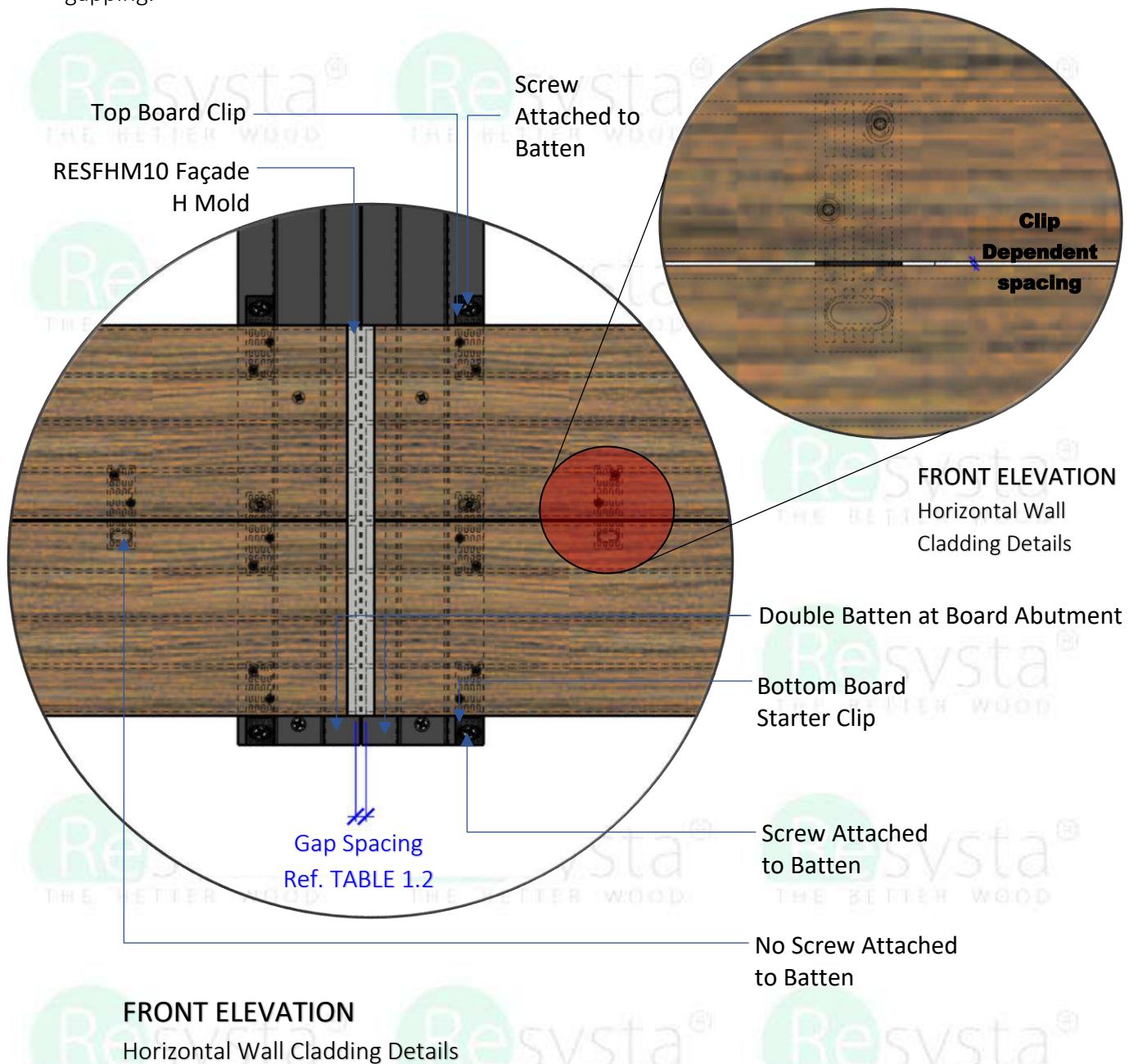

**Note :**

When connecting wall cladding boards at the ends, please consider Resysta Expansion from Table 1.3.

#### **STEP 4.1.4**

Follow Steps 3.4 and 3.6 from Section 3 until installation of the wall cladding is finished.

#### **Multi-Board Wide Installation using Continuous H-Channel Trim**

#### **STEP 4.2.1**

Ensure that two battens have been installed where the boards are to be installed end to end.

#### **STEP 4.2.2**

Follow steps 3.1 and 3.2 from Section 3 to install finishing trim and attach the first wall cladding board. An H-Channel Trim should be installed at each board abutment joint to cover the ends of the Resysta Wall Cladding Boards. This is an option for installation using 3 or more boards abutted end-to-end.

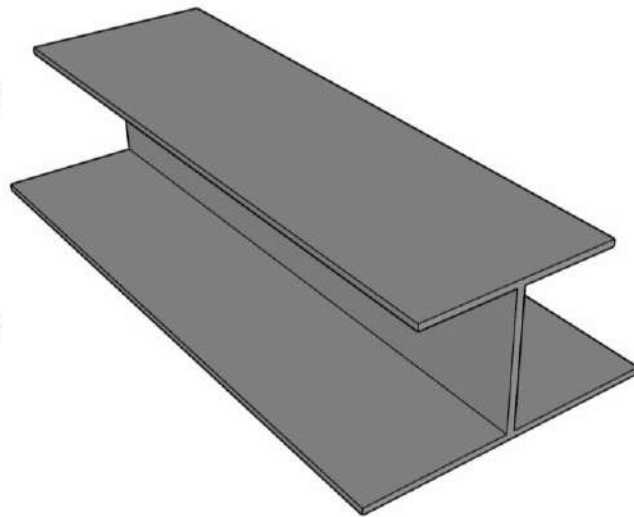

#### **STEP 4.2.3**

Install starter wall cladding board 3” from the ground with the provided HF Clips and screws.

#### **STEP 4.2.4**

Follow Step 4.1.3 and assure proper gapping between the wall cladding board and the H-Channel Trim.

#### **STEP 4.2.5**

Continue installing wall cladding boards as outlined in Section 4: “Multi-Board Wide Installation using Continuous H-Channel Trim”

**SECTION 5 – Vertical Wall Cladding Applications**

**STEP 5.1**

Pre apply all finishing trim accessories such as trim around corners, windows, and doors according to the pre plan layout and following the manufacture’s recommendations. Ensure that all trim is level and square. Battens should be installed horizontally.

**STEP 5.2**

Attach HF Clips with the integrated assembly stop to the back side of the wall cladding board with 2 #8 x ½” SMS screws. Clips need to be installed 16” apart to make sure they line up with the battens (just like in the horizontal installation).

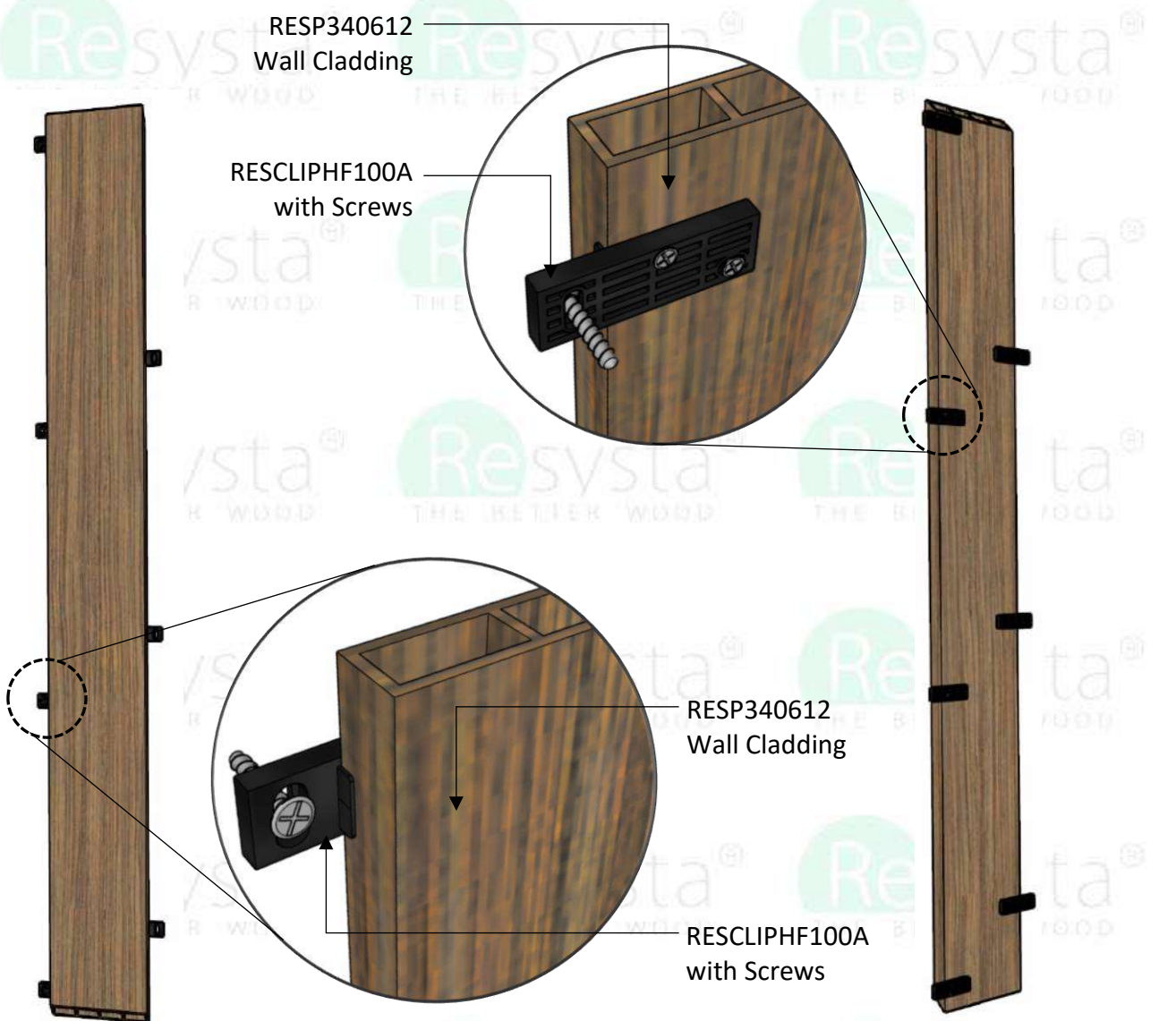

**FRONT ISOMETRIC VIEW**  
Vertical Wall Cladding Details

**REAR ISOMETRIC VIEW**  
Vertical Wall Cladding Details

### STEP 5.3

Fasten the first vertical wall cladding board using the provided screw to the horizontal battens.



### STEP 5.4

Attach HF Clips to both sides of the 2<sup>nd</sup> board. Make sure the clips on the abutting sides of the wall cladding boards don't line up.

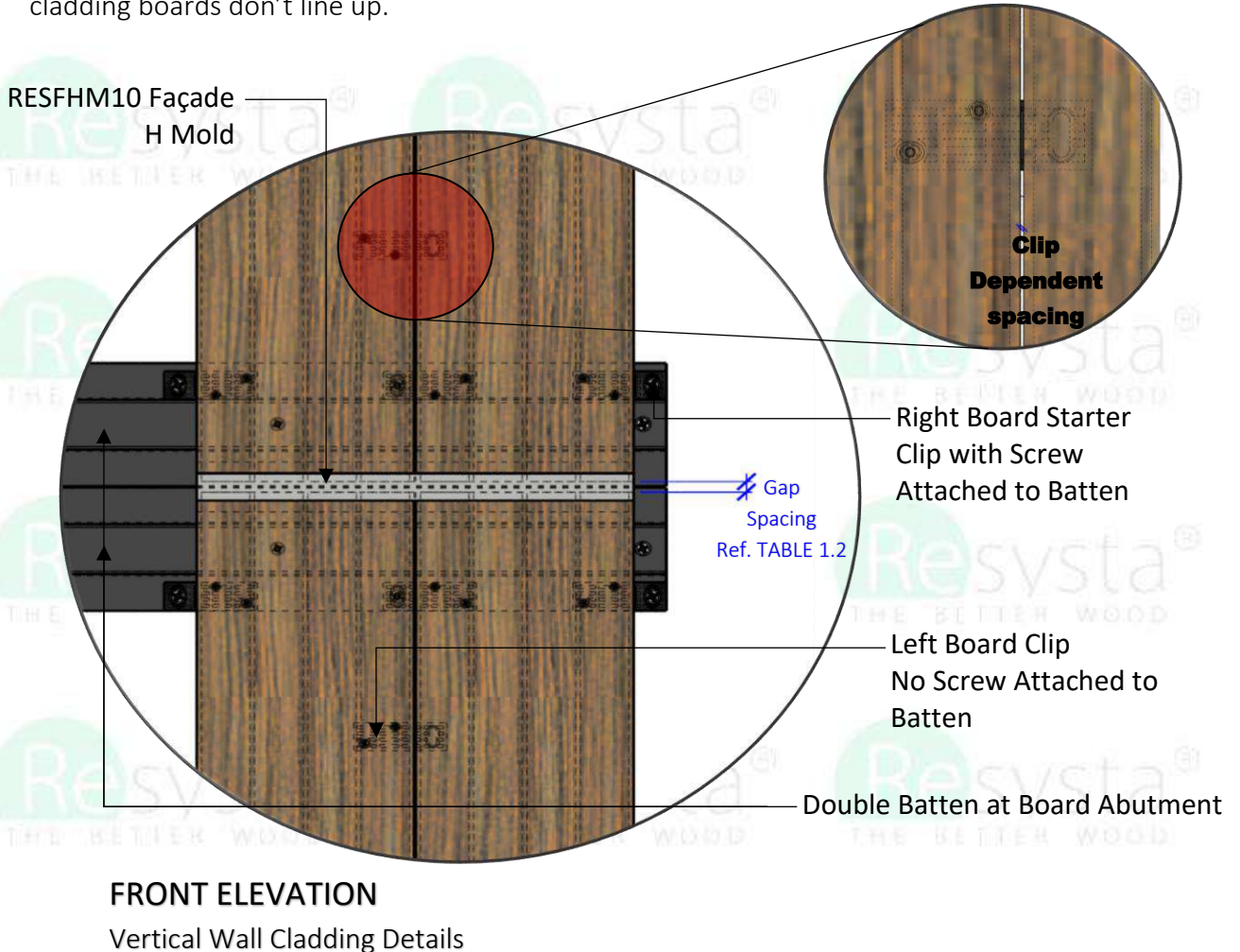

### STEP 5.5

Slide in the clips on one side of the 2<sup>nd</sup> wall cladding board into the gap behind the starter wall cladding board and fasten the visible clips on the wall cladding board to the battens.

RESCLIPHF100A  
with Screws

RESP340612  
Wall Cladding

RESFHTC10BA  
Hat Channel

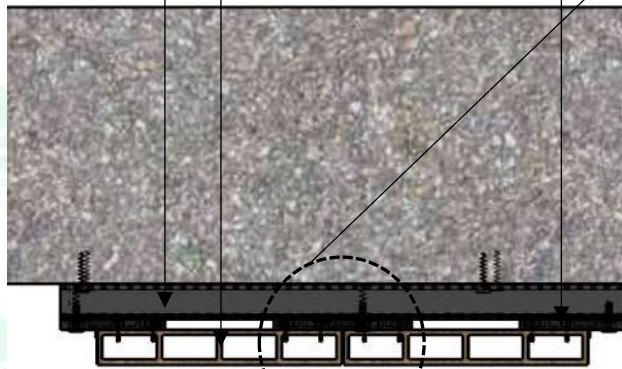

TOP VIEW

Vertical Wall Cladding Details

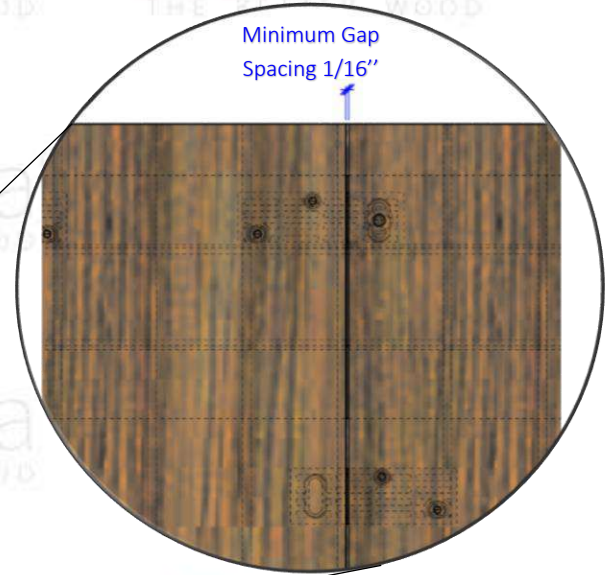

FRONT ELEVATION

Vertical Wall Cladding Details

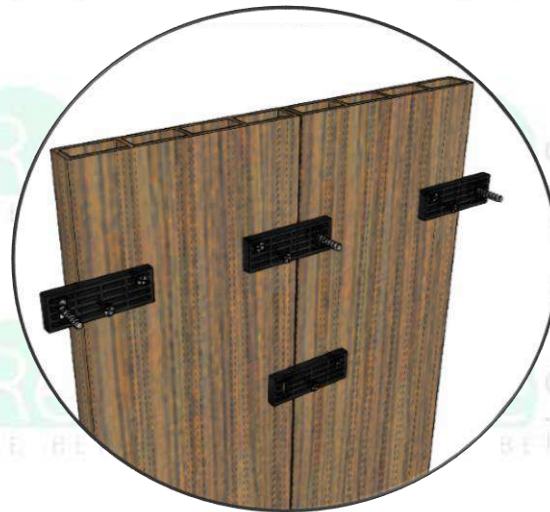

REAR ISOMETRIC VIEW

Vertical Wall Cladding Details

### STEP 5.6

Continue to install vertical boards like described in the Section 5 until wall cladding installation is finished.

**Special Requirement** – By following these installation guides for vertical installation methods ALL expansion and contraction will happen at the bottom of the board. Gap the bottom of the board properly based on installation needs.

**Note:**

If installing more than one board in height, please refer to Section 6 – Vertical Multi Board Wall Cladding Applications

**SECTION 6 – Multi-Board Vertical Wall Cladding Applications**

**2Board High Installation without the H-Channel Trim (24ft max Height)**

**STEP 6.1.1**

Ensure that two battens have been installed where boards are to be installed end to end.

**STEP 6.1.2**

Follow Steps 5.1 and 5.2, from Section 5 to install finishing trim, and attach the first wall cladding board.

**STEP 6.1.3**

Install the bottom wall cladding board first using recommended HF Clips just like in Section 5.

**STEP 6.1.4**

Install the top wall cladding board by butting it against the bottom wall cladding board and securing it with the provided HF clips. Use the Table 1.4 “Resysta Expansion” for reference to assure proper spacing between wall cladding boards.

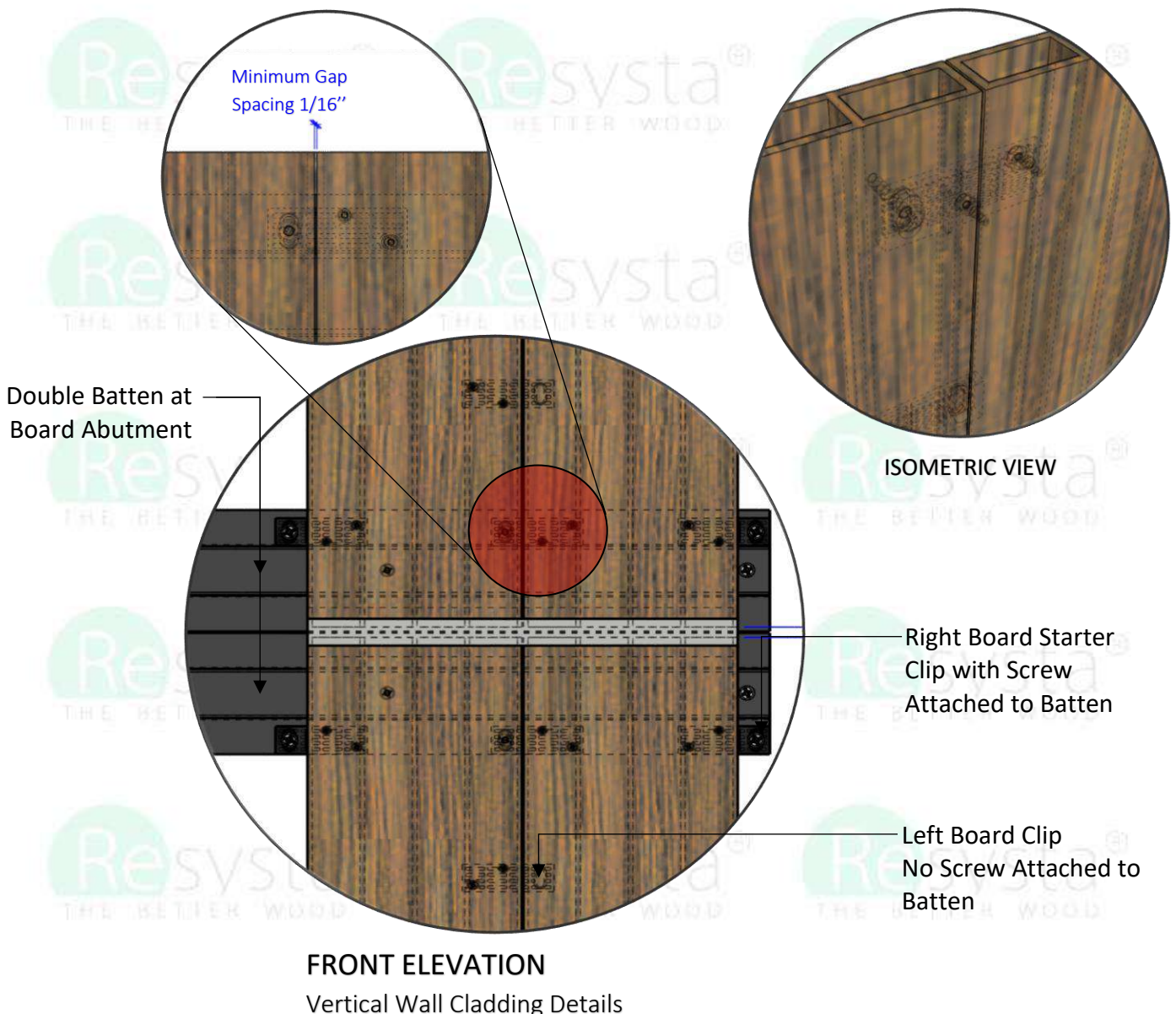

### **STEP 6.1.5**

Follow the steps 5.4 through 5.6 until the installation is finished

### **Multi-Board High Installation using the Continuous H-Channel Trim**

#### **STEP 6.2.1**

Ensure that two battens have been installed where boards are to be installed end to end.

#### **STEP 6.2.2**

Follow Steps 5.1 and 5.2, from Section 5 to install finishing trim, and attach the first wall cladding board. An H-Channel should be installed at each board abutment joist to cover the joints of the Resysta Wall Cladding board. This is a requirement for installation using 3 or more boards abutted end-to-end. None of the Wall Cladding Trim should be installed horizontally unless weep holes are drilled at 8" intervals to allow for moisture to escape from behind the face flange.

#### **STEP 6.2.3**

Install the bottom wall cladding board first using recommended HF Clips just like in Section 5.

#### **STEP 6.2.4**

Install the top wall cladding board by butting it against the H-Channel Trim and securing it with the provided HF clips. Use the Table 1.3 "Resysta Expansion" for reference to assure proper spacing between wall cladding boards and the H-Channel Trim.

#### **STEP 6.2.5**

Continue installing wall cladding boards as outlined in Section 6 until the wall cladding is finished.

**SECTION 7 – Air Barrier – Requirements**

For all of the installation options it is crucial to allow the uninterrupted flow of air from the bottom to the top of the wall system. This creates a chimney effect which provides not only moisture wicking but also cooling behind the Resysta wall cladding.

Air flow must be able to release at the top of the construction. For that reason a ½” gap between the top of the Resysta wall cladding board and the Parapet Wall Cap Flashing is necessary. The same size gap is needed between the face of the Resysta wall cladding board and the Parapet Wall Cap Flashing.

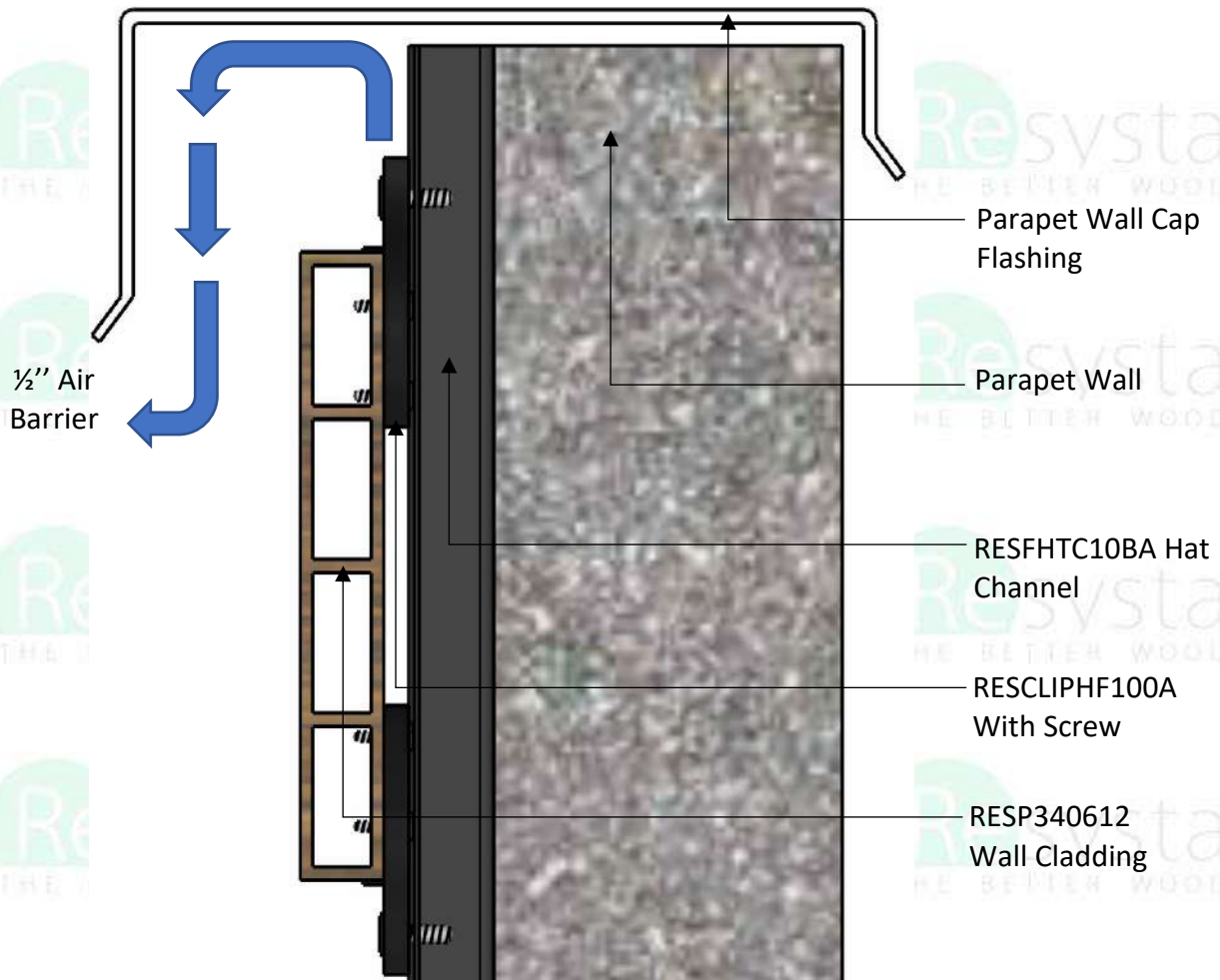

**SECTION**  
Wall Cladding Details

**SECTION 8 – Finishing Options – Trims and Hollow Cap**

**HORIZONTAL OUTSIDE CORNERS**

Outside corner trim should be pre applied prior to installing wall cladding boards. The wall cladding board end that is inserted into the outside corner should be miter cut at a 45 degree angle to match up with the outside corner internal web. Follow the gap guide when installing the wall cladding board to allow for expansion and contraction within the outside corner trim. Install horizontal wall cladding per previous sections. When using metal batten for an outside corner application, installer may have to cut off a single flange of the metal batten to secure the outside corner trim on both sides of the corner.

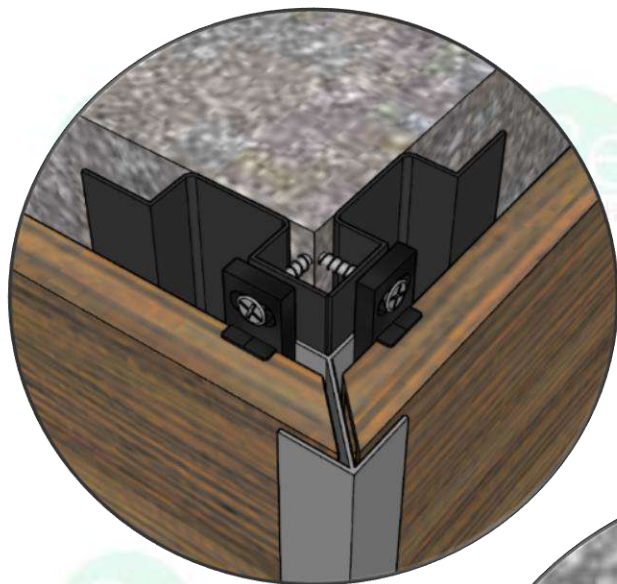

**ISOMETRIC VIEW**  
Horizontal Outside Corner

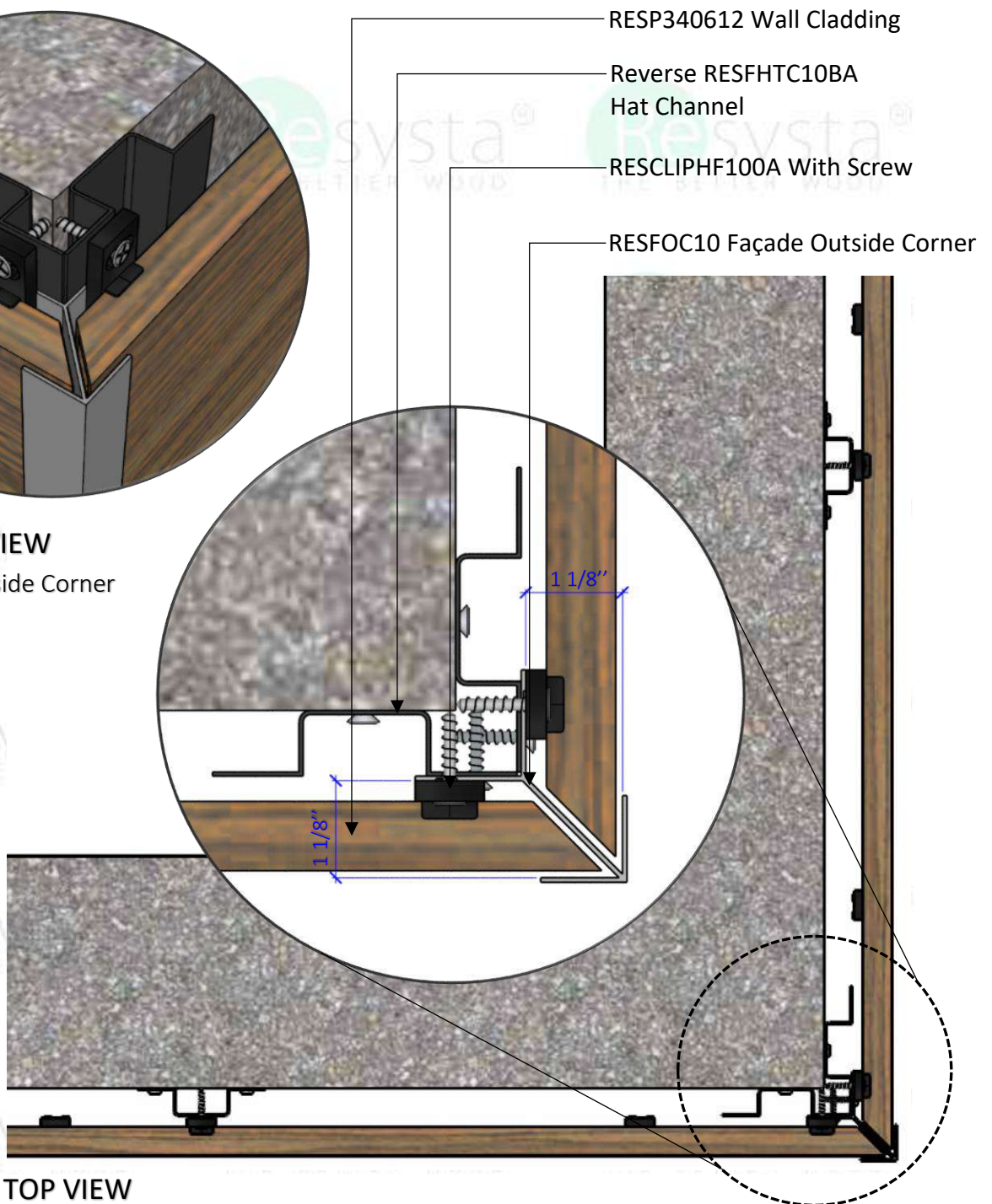

**TOP VIEW**  
Horizontal Outside Corner

## WALL CLADDING HORIZONTAL BUTT JOINT OUTSIDE CORNER

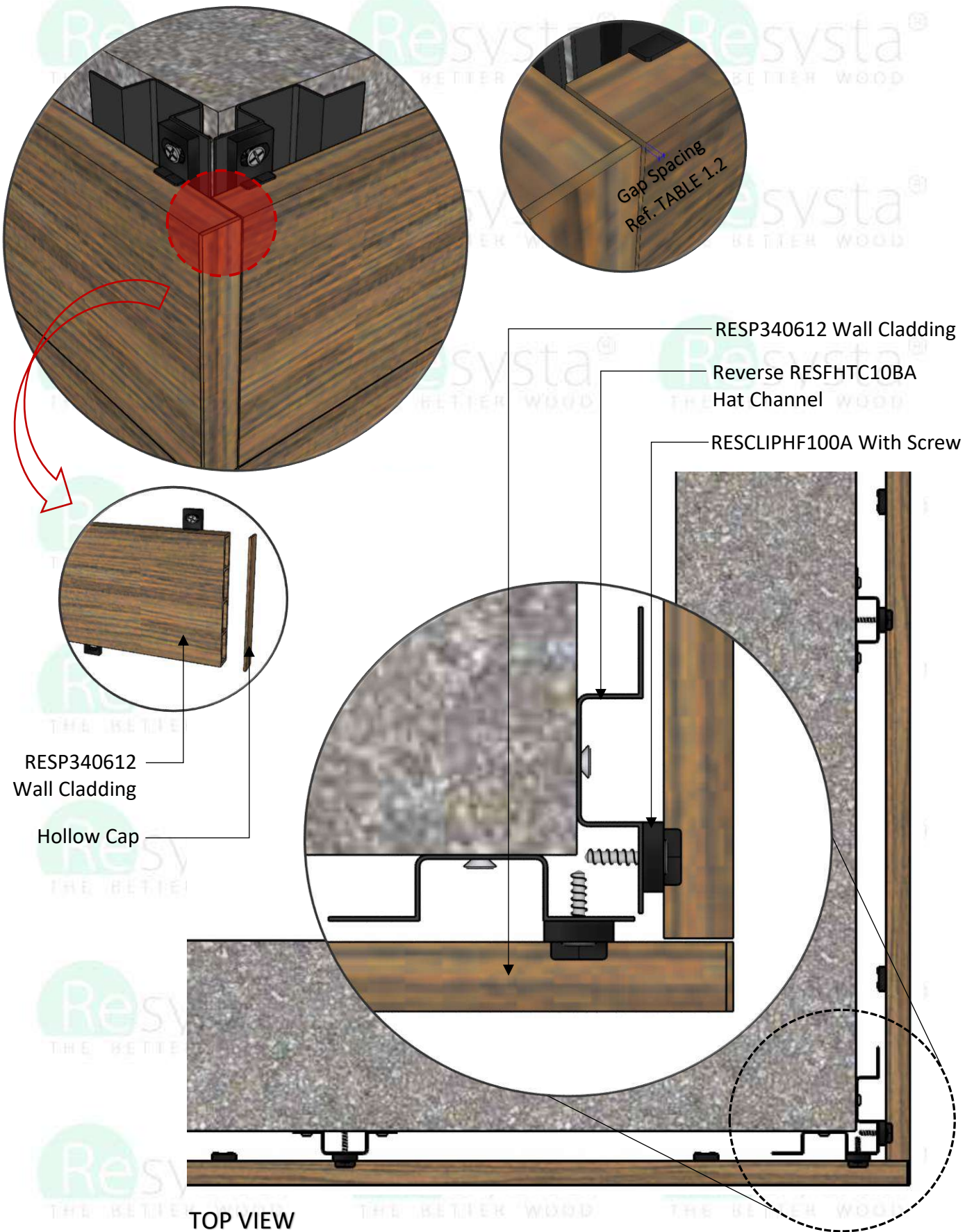

**TOP VIEW**  
Horizontal Butt Joint Outside Corner

## HORIZONTAL INSIDE CORNERS

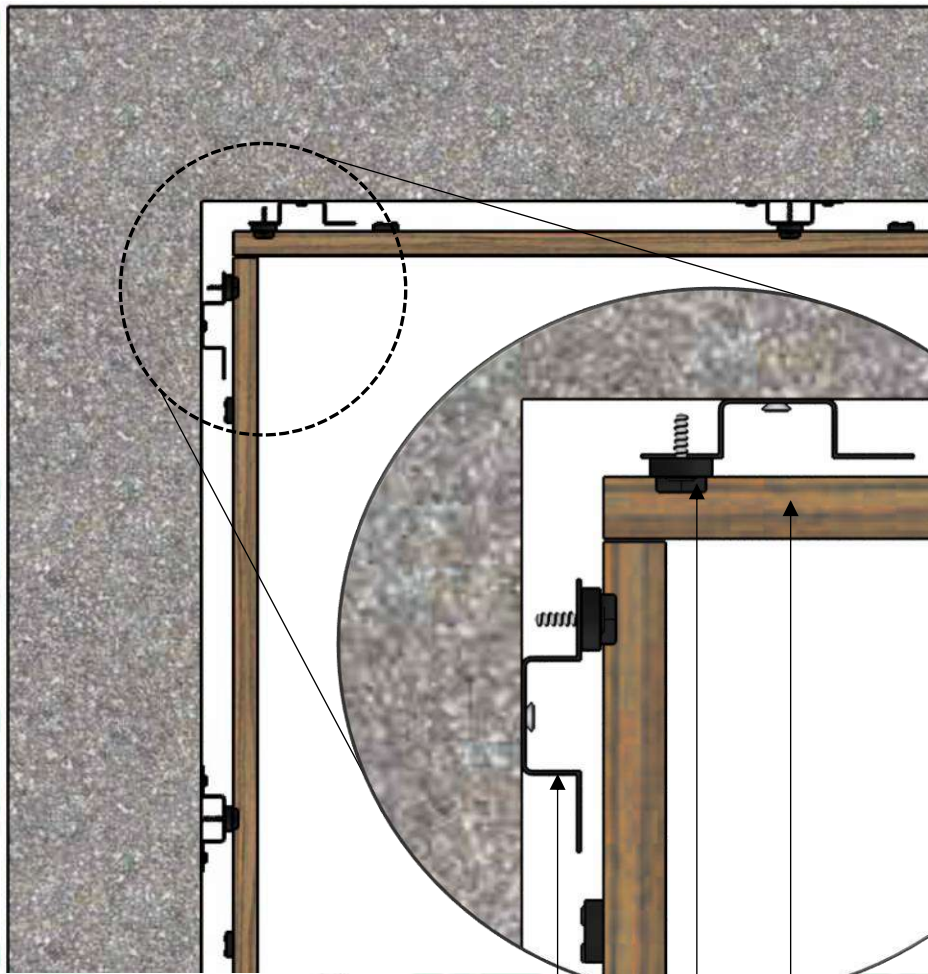

TOP VIEW

Horizontal Butt Joint Inside Corner

RESP340612 Wall Cladding

RESCLIPHF100A With Screw

RESFHTC10BA Hat Channel

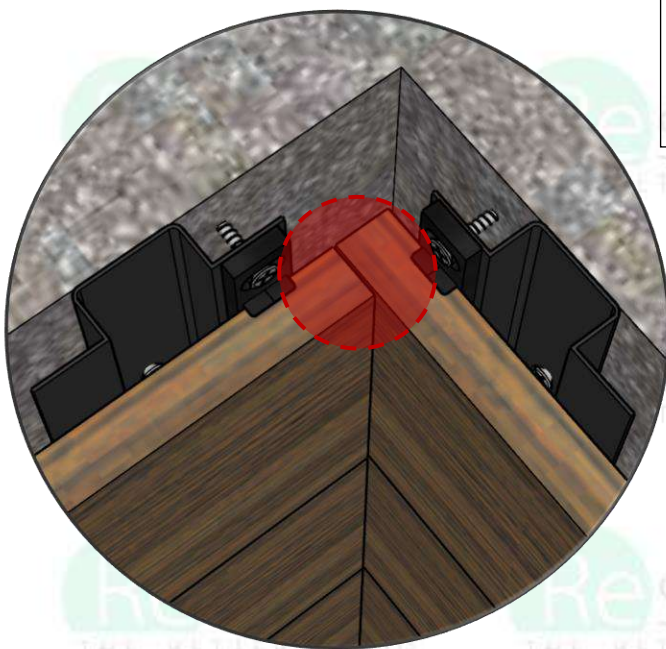

ISOMETRIC VIEW

Horizontal Butt Joint Inside Corner

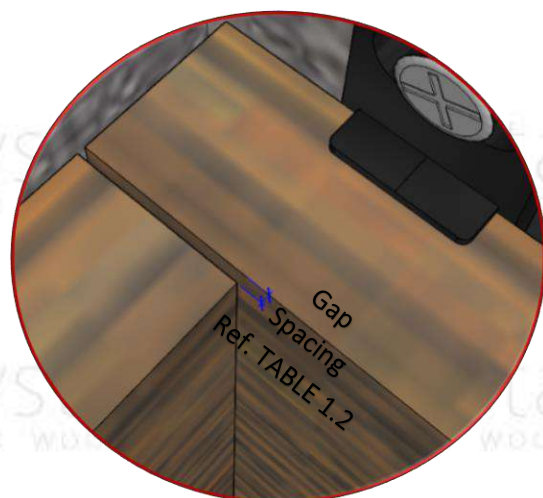

## VERTICAL OUTSIDE CORNERS

Outside corner trim should be pre-applied prior to installing wall cladding boards. Install the vertical wall cladding boards per previous sections. When using metal batten for an outside corner application, installer may have to cut off a single flange of the metal batten to secure the outside corner trim on both sides of the corner.

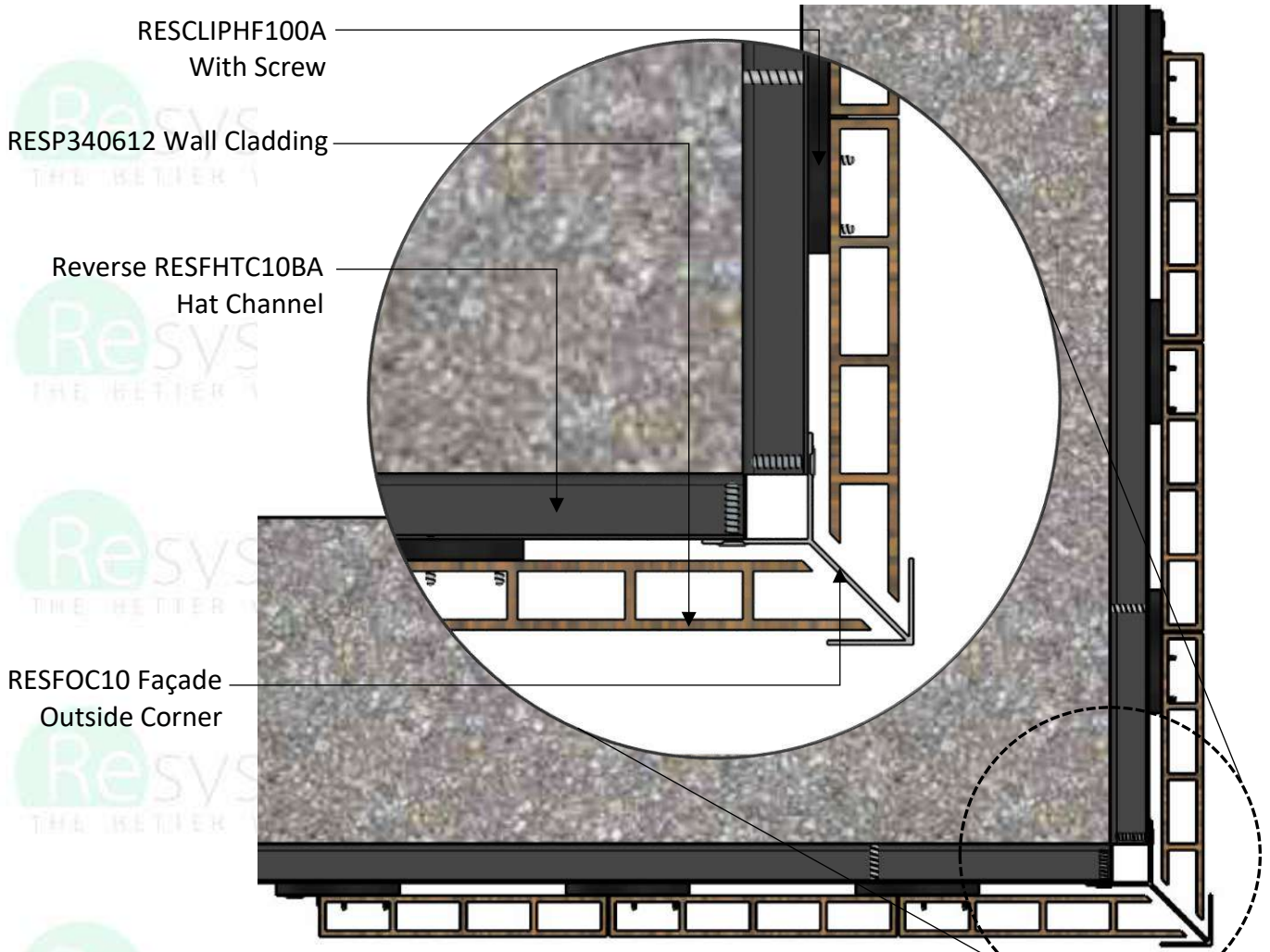

**TOP VIEW**  
Wall Cladding Vertical Outside Corner

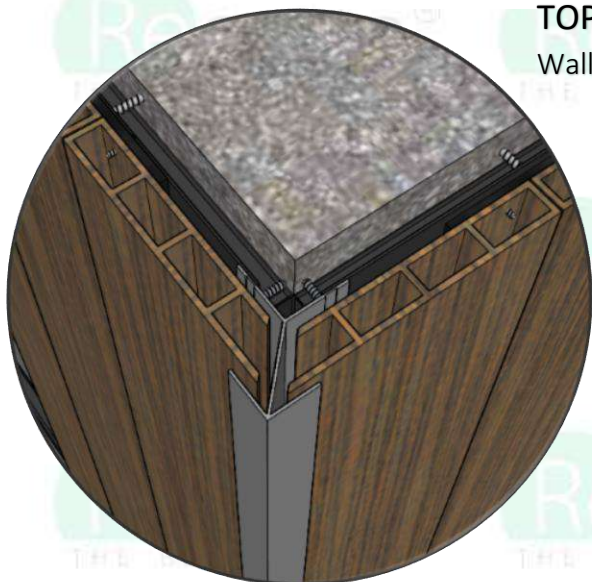

**ISOMETRIC VIEW**  
Wall Cladding Vertical Outside Corner

## VERTICAL INSIDE CORNERS

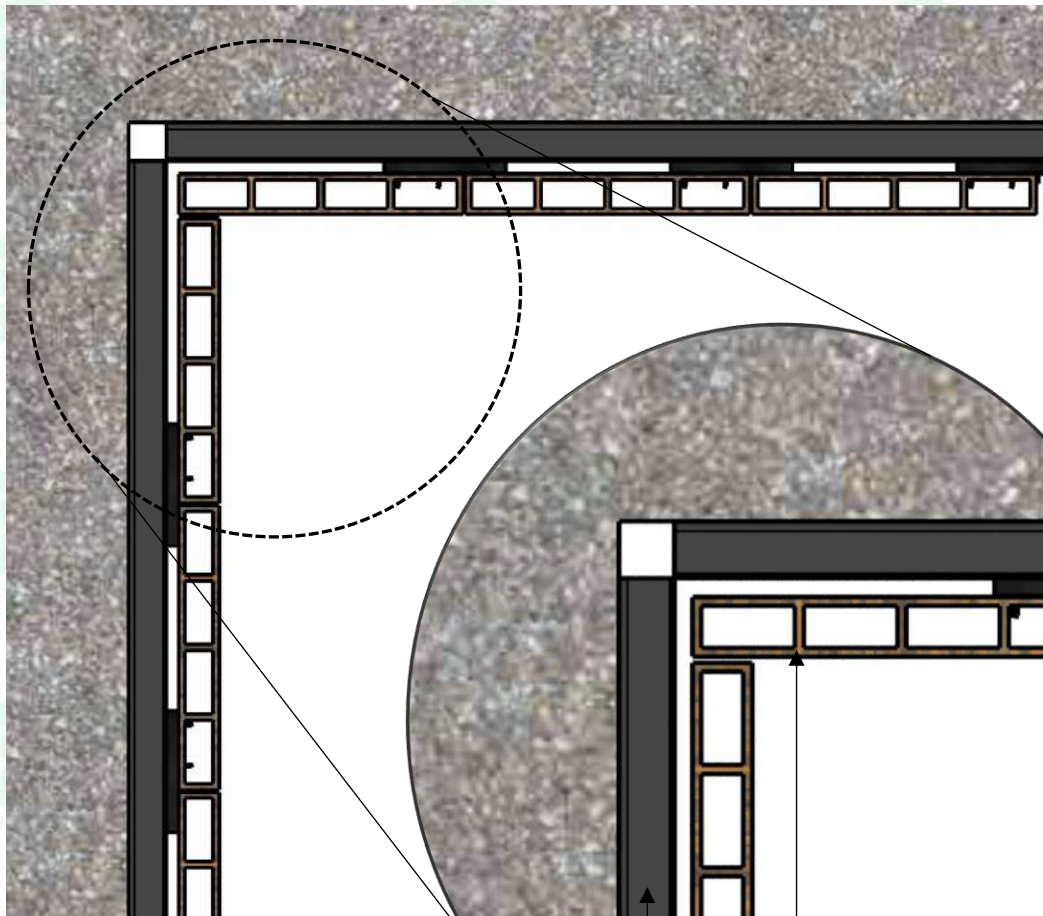

TOP VIEW

Vertical Butt Joint Inside Corner

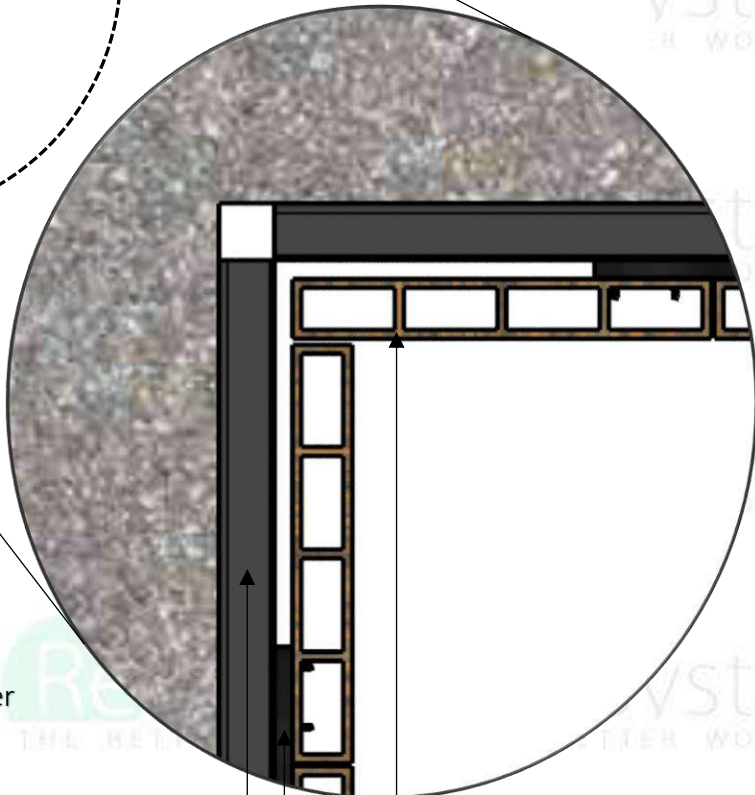

RESP340612 Wall Cladding

RESCLIPHF100A With Screw

RESFHTC10BA Hat Channel

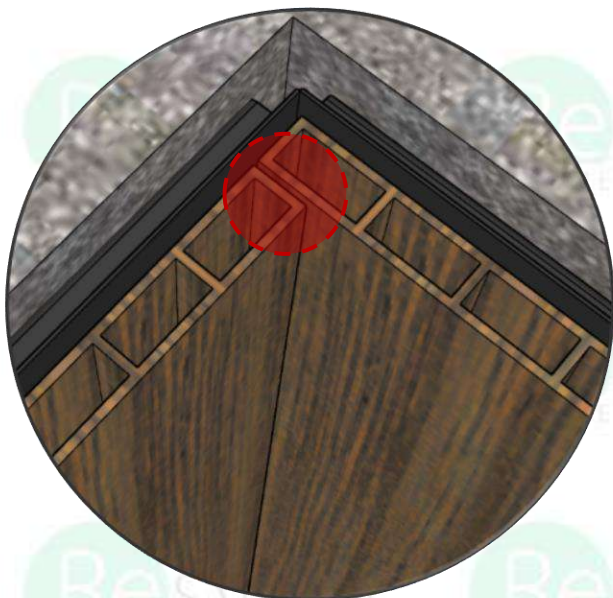

ISOMETRIC VIEW

Vertical Butt Joint Inside Corner

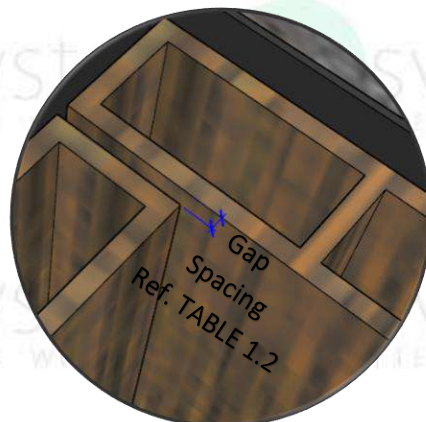

## HOLLOW CAP

Be sure that all surfaces are clean and free of debris such as dust, dirt, oils and paints. Remove adhesive strip cover film. Center Hollow Cap on the end of the plank and apply with firm pressure all around the center supports.

In the event that you will apply Hollow Cap on both ends of plank you must supply a vent hole in the back of each channel, I.E. drill a 1/8" hole in the back of the plank where it will not be viewed. For the four channel wall cladding profile you must drill 4 holes - one in each channel. This will allow any heat to be released preventing bulging of the cap on the hollow channel profiles.

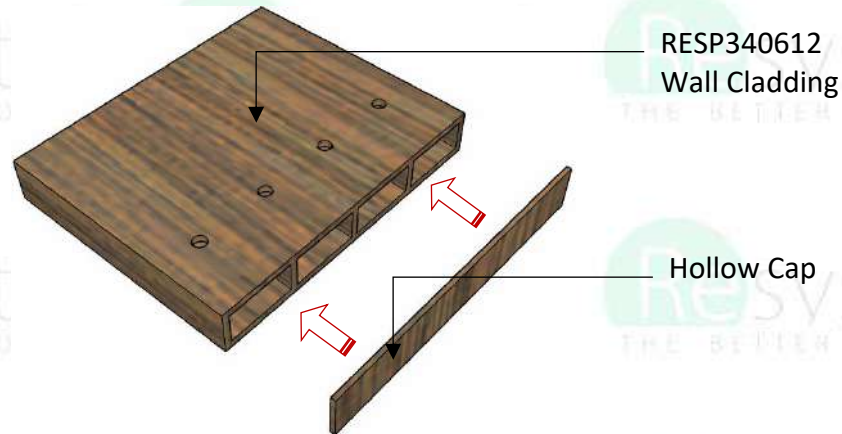

## BOARD TERMINATION TRIM

When a wall cladding board in either a horizontal or vertical application terminates into a wall, eave, window, door etc. a J-channel should be used to cover the exposed end of the wall cladding board. The J-channel should also be used along the bottom of a vertical installation. J-channel trim should be pre-applied prior to installing wall cladding boards. In the case of an intersecting joint the starter strip should be installed butted against the J-channel trim, not overlapping the J-channel trim attachment flange. Follow the gap guide when installing the wall cladding board to allow for expansion and contraction within the J-channel trim.

## HORIZONTAL APPLICATION

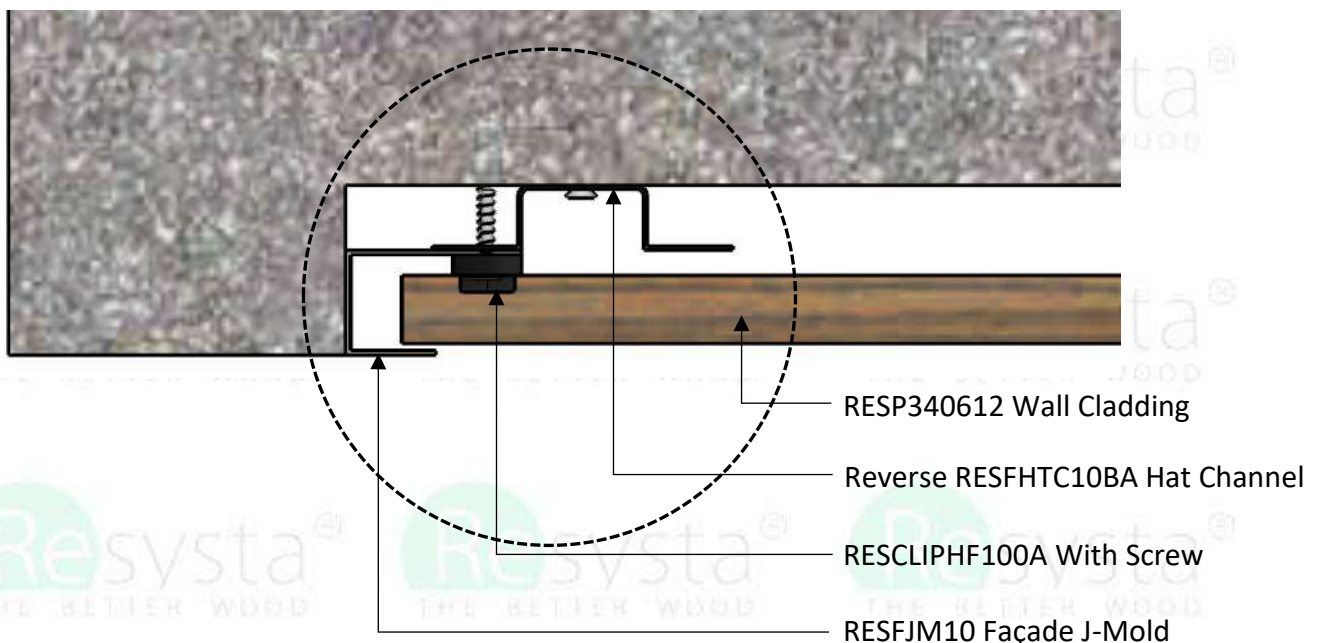

### TOP VIEW

Vertical Wall Cladding Details

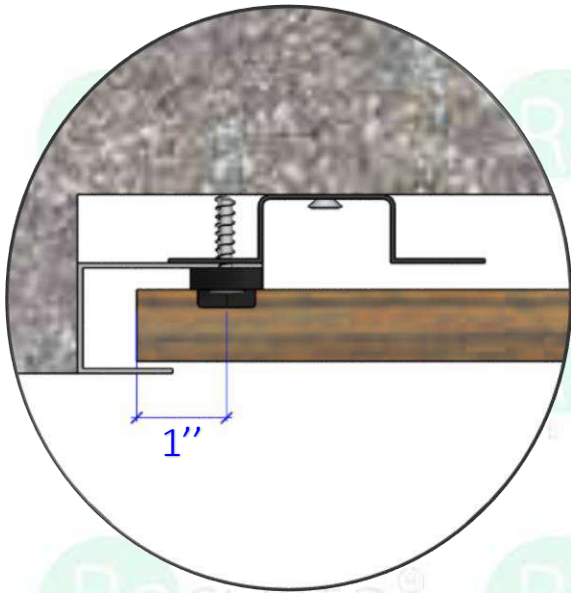

**TOP VIEW**

Vertical Wall Cladding Details

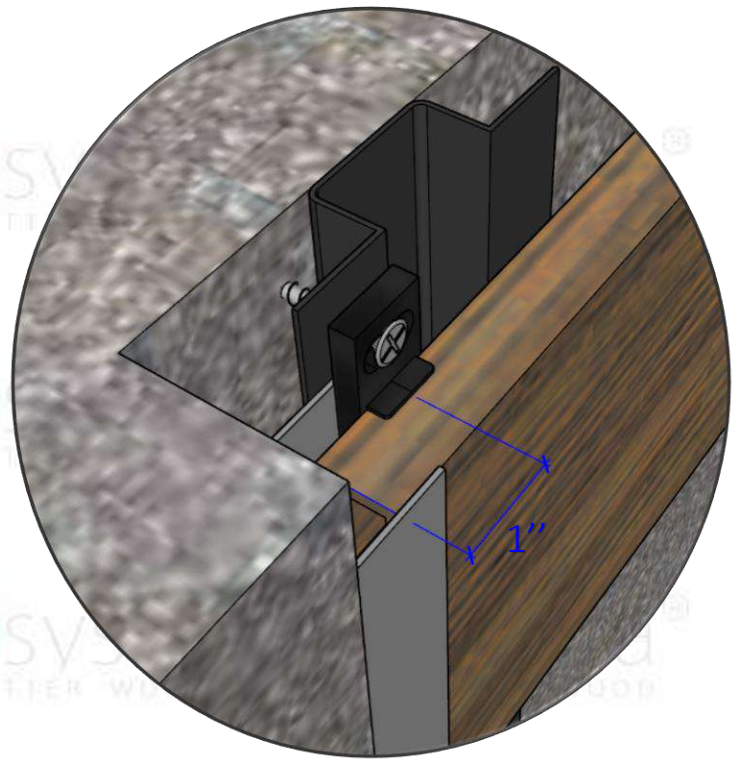

**ISOMETRIC VIEW**

Vertical Wall Cladding Details

### **SECTION 9 – Primer and Sealer System**

Resysta recommends using approved water-based primer RBP and stain RCL system.

### **3. Safety Warning**

Resysta<sup>®</sup> Products do not present an inhalation, ingestion, or contact health hazard unless subjected to operations such as sawing, sanding, or machining which result in the generation of airborne particulate. This product contains crystalline silica. Respirable crystalline silica limits are specified by OSHA. Exposure to respirable (fine) silica dust depends on a variety of factors, including activity rate (e.g. cutting rate), method of handling, ventilation, environmental conditions (e.g. weather conditions, workstation orientation), and engineering control measures used. Exposures to respirable crystalline silica above limits established by OSHA are not expected during the normal use of this product. Crystalline silica, has been shown to cause silicosis, and has been identified by the State of California, IARC and NTP as a known human carcinogen. The risk of developing silicosis is dependent upon the exposure intensity and duration. It is recommended that a NIOSH approved particulate respirator be worn whenever working with this product results in airborne dust exposure.

Please direct product inquiries to:

Resysta North America, Inc.

4035 Cheyenne Ct.

Chino, CA. 91710

Tel: 909-393-2888

Email: [info@resystausa.com](mailto:info@resystausa.com)