



INSTALLATION GUIDE

RESYSTA RHOMBUS QUIK-TRIM SYSTEM



I. Introduction

SECTION 1

Material Components

SECTION 2

Basics

SECTION 3

Scope of Delivery

II. Installation Procedure

SECTION 1

Batten Substructure

SECTION 2

Trim and Accessory Option

SECTION 3

Horizontal Rhombus Application

SECTION 4

Multi-board Horizontal Rhombus Application

SECTION 5

Vertical Rhombus Application

SECTION 6

Multi-board Vertical Rhombus Siding Application

SECTION 7

Air Barrier Requirements

SECTION 8

Finishing Option - Trims and Hollow Cap

SECTION 9

Prime and Stain System

III. Safety Warning

I. INTRODUCTION

Resysta is an extremely durable, timber look-alike, decking material. It is resistant to damage from the sun, rain, frost and even salt water. Unlike wood, it requires minimal maintenance and is highly resistant to pests, mold and cracks. Unlike other composite materials, it closely resembles the look and feel of natural wood, with a smooth surface finish. Resysta meets most of the future environmentally sustainable material requirements concerning recycled and fully recyclable materials. Resysta is used for its architectural aesthetic, and not for structural support.

SECTION 1 - Material Components

A combination of these three basic raw materials makes up the simple components that create Resysta. This innovative material offers designers and architects new creative horizons to utilize its compelling and unique appearance.



Approx. 60% RICE HUSK + Approx. 22% COMMON SALT + Approx. 18% MINERAL OIL = RESYSTA

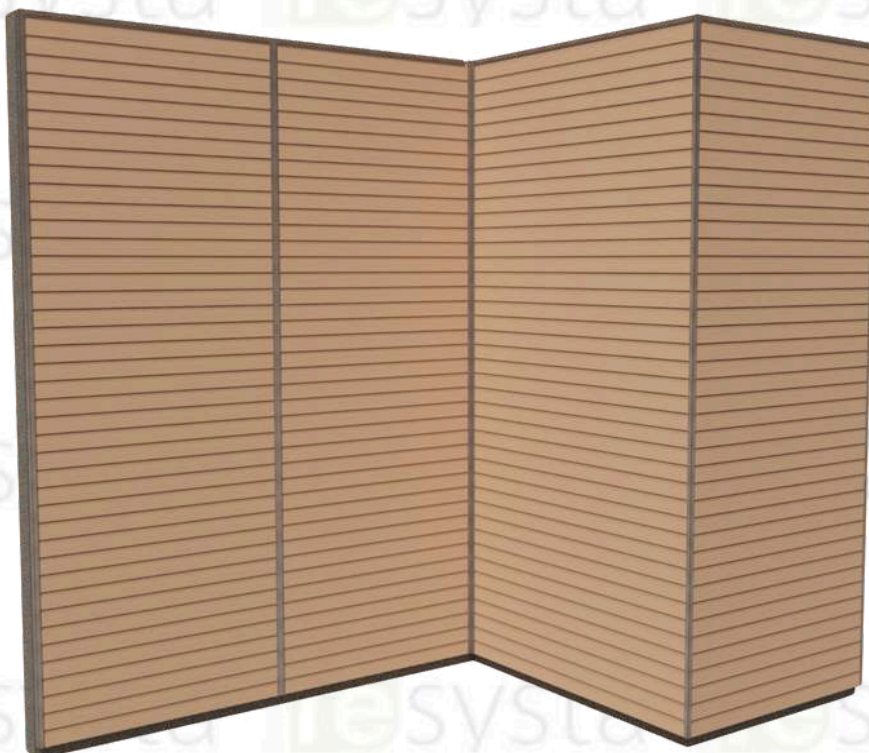

OVERVIEW OF PARTS

SECTION 2 - Basics

RESSHTC10P
Hat Channel

RESCPSS25
Shoulder SS Screw

RESYSTA
Rhombus Profile

QTOC10
Quik-Trim
Outside Corner

QTJM10
Quik-Trim J-Mold

QTWJM10
Quik-Trim
Windows J-Mold

QTHM10
Quik-Trim H-Mold

QTIC10
Quik-Trim
Inside Corner

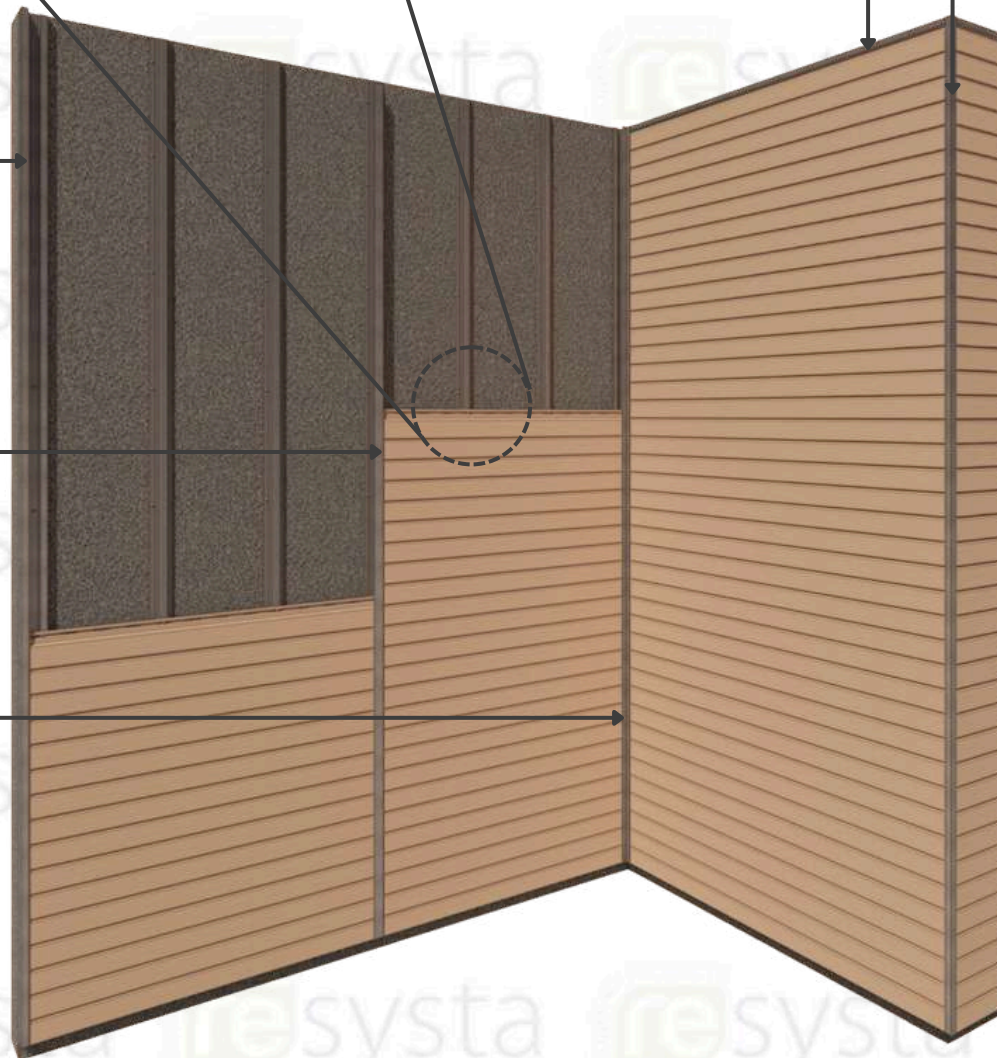
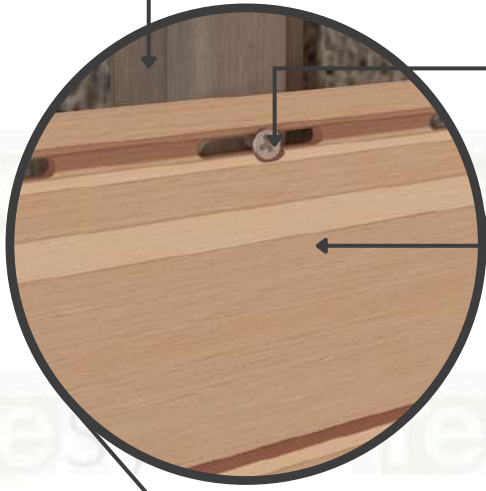

ISOMETRIC VIEW

Basic Parts of Rhombus Board Quik-Trim System

SECTION 3 - Scope of Delivery

NO.	PRODUCT NAME AND SPECIFICATION	ISOMETRIC VIEW	SECTION VIEW
1	RESRPH340312 3/4" x 3" x 12' 3" Rhombus Profile		
2	RESSHTC10 3/4" X 1 1/2" Siding Hat Channel Mill Finish		
3	RESSHTC10P 3/4" X 1 1/2" Siding Hat Channel Punched Mill Finish		
4	QTWJM10 1" x 1-37/64" J Quik-Trim Windows J-Mold with Quik-Trim PVC Base		
5	QTOC10 1" x 1" Quik-Trim Outside Corner with Outside Corner Quik-Trim PVC Base		
6	QTIC10 1-37/64" x 1-37/64" Quik-Trim Inside Corner with Quik-Trim PVC Base		

Scope of Delivery

NO.	PRODUCT NAME AND SPECIFICATION	ISOMETRIC VIEW	SECTION VIEW
7	QTHM10 1-37/64" Quik-Trim H-Mold with Quik-Trim PVC Base		
8	QTJM10 1" x 25/32" Quik-Trim J-Mold with Quik-Trim PVC Base		
9	RESSJS10 Starter J-Strip		
10	RESCPSS25 1" TEC Shoulder Stainless Steel Screw		

Table 1.1 "Scope of Delivery"

NOTE:

To view a complete list of products, please refer to our Resysta brochure or visit our website www.resysta.com.

IMPORTANT: Major Bullet Points You Must Follow for a Successful Resysta Rhombus Installation

- Screw Placement
- Room for Expansion and Contraction
- Hard Fastening of each Plank
- Top to Bottom Ventilation

Note:

Proper planning of the rhombus board layout is essential for ease of installation of rhombus board and rhombus board components. Thoroughly read the following rhombus assembly instructions and obtain all necessary building permits prior to starting your installation. Decide finishing and trimming options prior to starting the project to ensure the rhombus finishing detail is uniform for all sides of the building. Installation is the sole responsibility of the installer. Resysta Company assumes no responsibility whatsoever with respect to the installation. The information contained herein is provided for guidance purposes only and should not be relied upon as an absolute representation by Resysta.

Packed finished material must be kept dry.



When packed, finished Resysta products are exposed to moisture, it can develop mold/mildew on the board surfaces if left packed/bundled..

If packed material is exposed to moisture, open immediately and spread material to allow surfaces to dry.

This condition only applies to packed material. Finished Resysta products installed in exterior applications will not exhibit this issue.

Safety Tips:

1. Always check for power, gas, and water lines before installing.
2. Always wear safety glasses when operating power equipment.

Assembly Tips:

1. Battens should be flat and level with each other. The rhombus will follow the contour of the wall.
2. Resysta rhombus system is not a rainscreen or waterproof system. Resysta rhombus is a watershed system.
3. Proper wall preparation according to local building codes and wall covering manufacturer's recommendations should be adhered to. This includes but is not limited to flashing all openings.
4. All holes should be predrilled and installation holes should be slotted.
5. Only use construction fastening material and hardware suitable for outdoor use (e.g. stainless steel screws). Recommended is the use of RESCPSS25 shoulder screw.
6. Always consider the linear expansion of Resysta, which is dependent on the temperature but not the air humidity. See Table 1.2 "Resysta Expansion" for more information.
7. Cut-off pieces and/or abrasive dust must be disposed of separately. Please comply with the regulations of your competent waste management. You may under no circumstances burn Resysta material.
8. Cutting to length should be carried out at consistent material temperature. Therefore, the material should be stored in the shade or in areas where it is not exposed to direct sunlight. The material can warm up considerably in the sun, leading to an increased change in length. In the case of more distinct fluctuations in material temperature, cutting to length may have to be adapted accordingly.
9. Please store Resysta products flat on a level surface.



MANDATORY VENTILATION

Cross ventilation (also called Wind Effect Ventilation) is a natural method of cooling. The system relies on wind to force cool exterior air into the building through an inlet (like a wall louver, a gable, or an open window) while outlet forces warm interior air outside (through a roof vent or higher window opening).

In Resysta Rhombus Installation, the 3" Gap at the bottom part of Rhombus System acts as the cool exterior air INLET while the 1/2" Gap on top acts as the warm interior air OUTLET. The air gap between wall surface and rhombus boards resultant from the battens sub frames height allows passage air flow for cross ventilation through the RHOMBUS QUIK TRIM INSTALLATION SYSTEM.

ADJACENT SURFACE

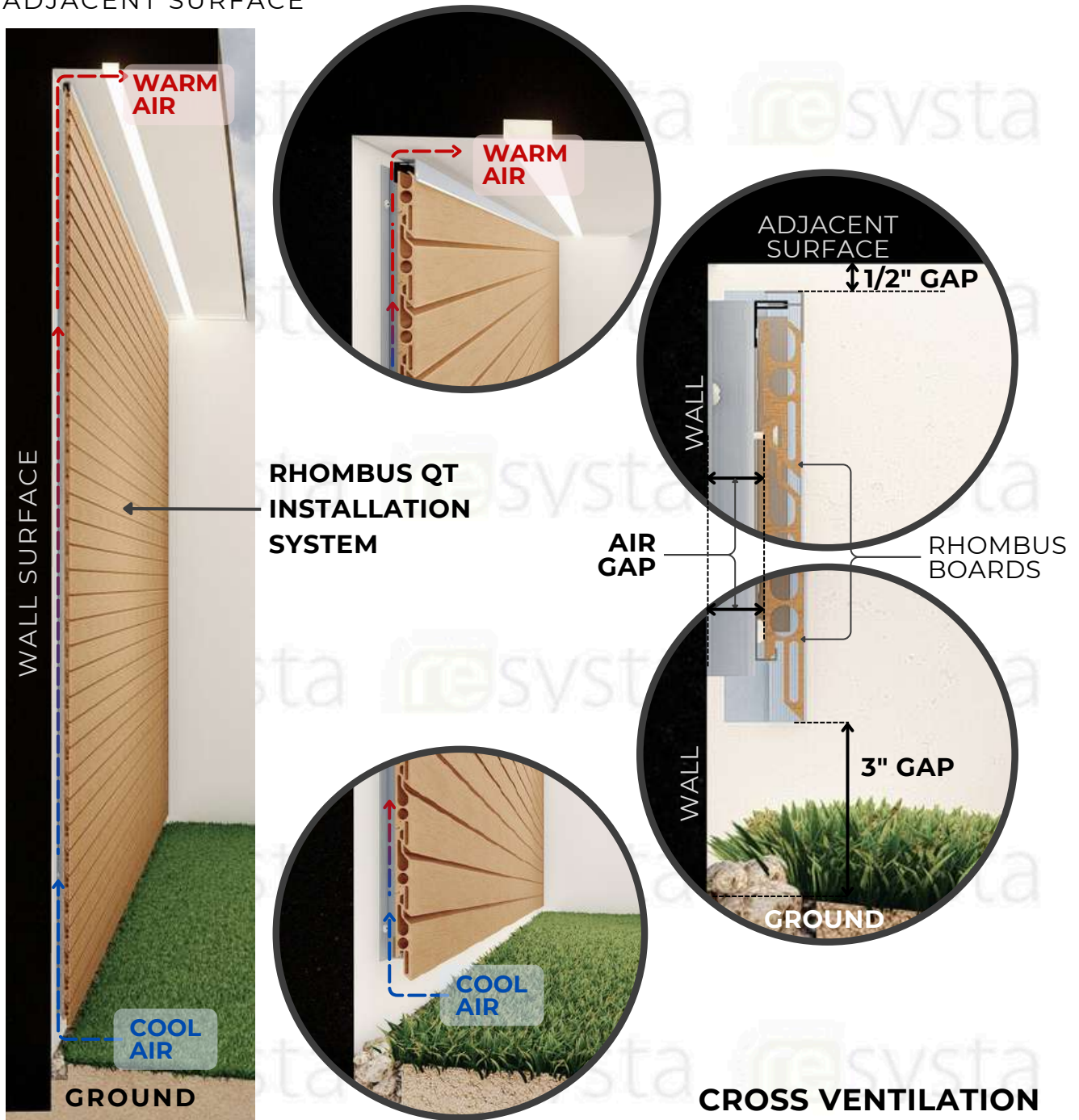

CROSS VENTILATION
Rhombus Quik-Trim System

Code Compliant Batten Spacing

Part Number	Part Description	Batten Span (in)	Minimum Steel Gage Size
RESRPH340312	3" Rhombus Profile (3/4" x 3")	16"	18

Table 1.2 "Batten Spacing Requirements"

Recommendation for Batten Spacing

If the rhombus board is being installed in a hot southern location and will be exposed to direct sunlight for the majority of each day and/or the rhombus will be stained a dark color, the batten spacing is suggested to be reduced to 8" or 12" center-to-center for all rhombus board.

Expansion / Contraction of Rhombus Profile

Resysta Expansion – Contraction Guide	
Profile Length	12 ft
Expansion / Contraction amount (approx.. 0.3% over 90°F variation in temperature)	7/16" (0.432")

Table 1.3 "Resysta Expansion"

Ensure a steady material temperature when cutting the boards to size, i.e. the cutting has to be done under constant conditions, e.g. inside or in shade.

Always consider the linear expansion of Resysta during the installation of rhombus profile products. If temperatures fluctuate during the installation, the gaps placed between the ends of the boards and a corner, window, or door must change with the temperature. Use the guide above to gap boards during installation.

Resysta Rhombus Profile Board Gap Guide					
	Trim Gap of Rhombus Profile Board				H-Channel Gap
Temperature at Installation	Below 30° F	60°F	90°F	120°F	
Amount for Rhombus Profile Length of 12 ft.	7/16"	5/16"	3/16"	0"	1/4"

Table 1.4 "Resysta Expansion"

Ensure a steady material temperature when cutting the boards to size, i.e. the cutting has to be done under constant conditions, e.g. inside or in shade.

Expansion – Contraction Tips:

1)Control Piece

at the start of the day cut a length of board that is desired to be installed and keep this board in the same area as the cutting and storage of the remaining boards. This board will be a “Control Piece” to reference when cutting other boards to be installed. Throughout the day the “Control Piece” can be referenced and the saw cuts adjusted accordingly as the boards expand and/or contract. The heat from the sun will cause Resysta boards to expand so if the material is stored in the shade keep the “Control Piece” in the shade as well.

Example:

If 12ft boards are being installed put aside one 12ft board at the start of the day. Reference these boards throughout the day and adjust the cutting of the other boards to match.

2)Control Gap

at the start of the installation place the board gap according to Table 1.4 and mark the first gap made. This gap will be a “Control Gap” to reference when gapping the remaining boards to be installed. Throughout the installation reference back to this “Control Gap” to match the other gaps being installed. This will ensure that all the gaps installed are the same.

II. INSTALLATION - PROCEDURE

SECTION 1 - Batten Substructure

General Notes on Batten Substructure

Resysta rhombus board can be installed in horizontal or vertical applications and the batten substructure should be planned to accommodate how the rhombus board will be installed.

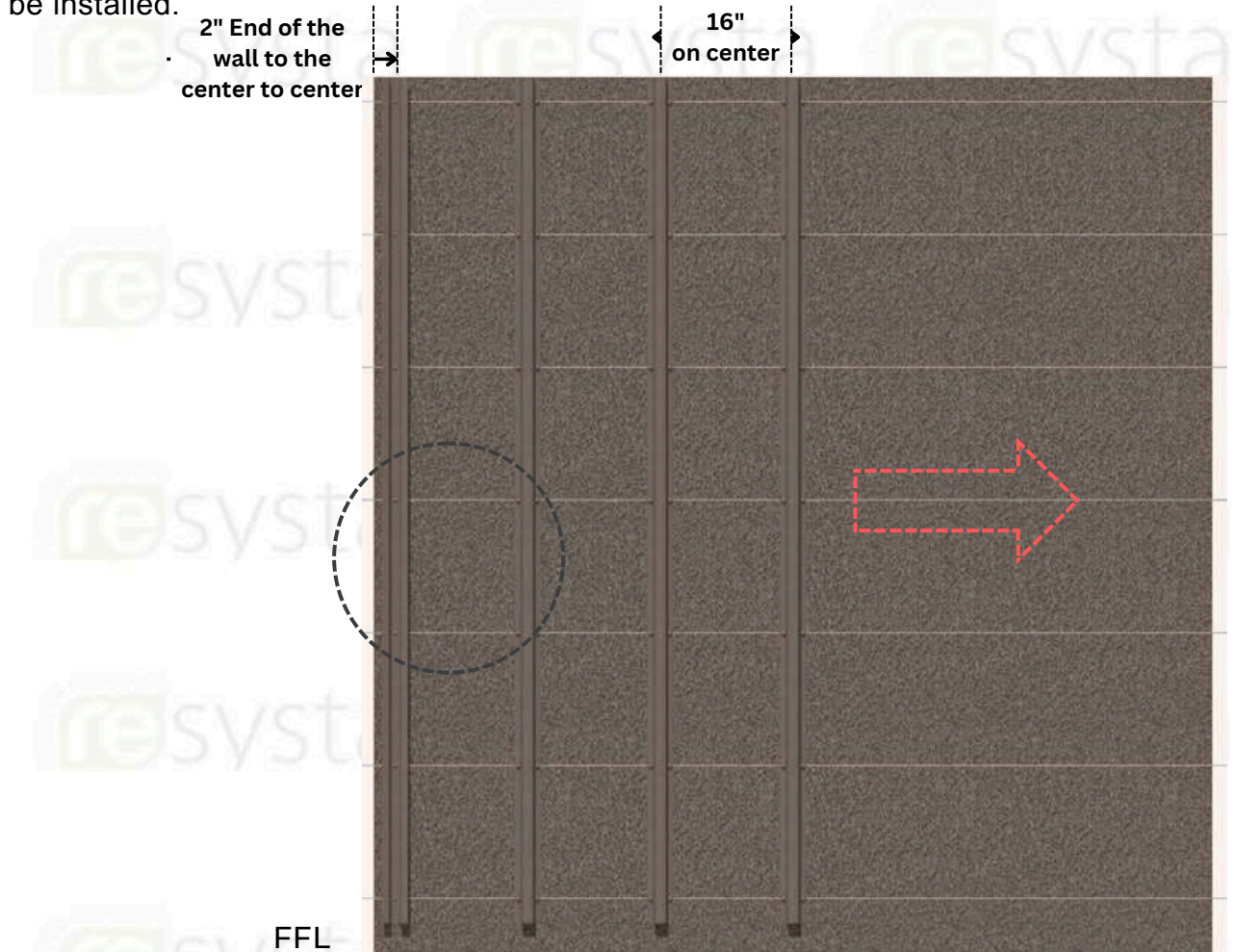

FRONT ELEVATION
Quik-Trim System

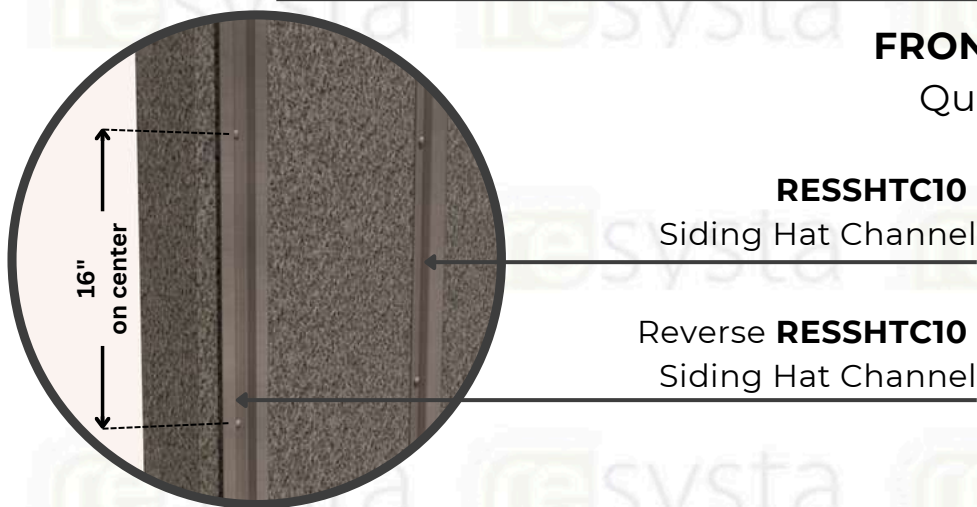

DETAIL
Quik-Trim System

Reverse
RESSHTC10
Siding Hat
Channel

RESSHTC10
Siding Hat
Channel

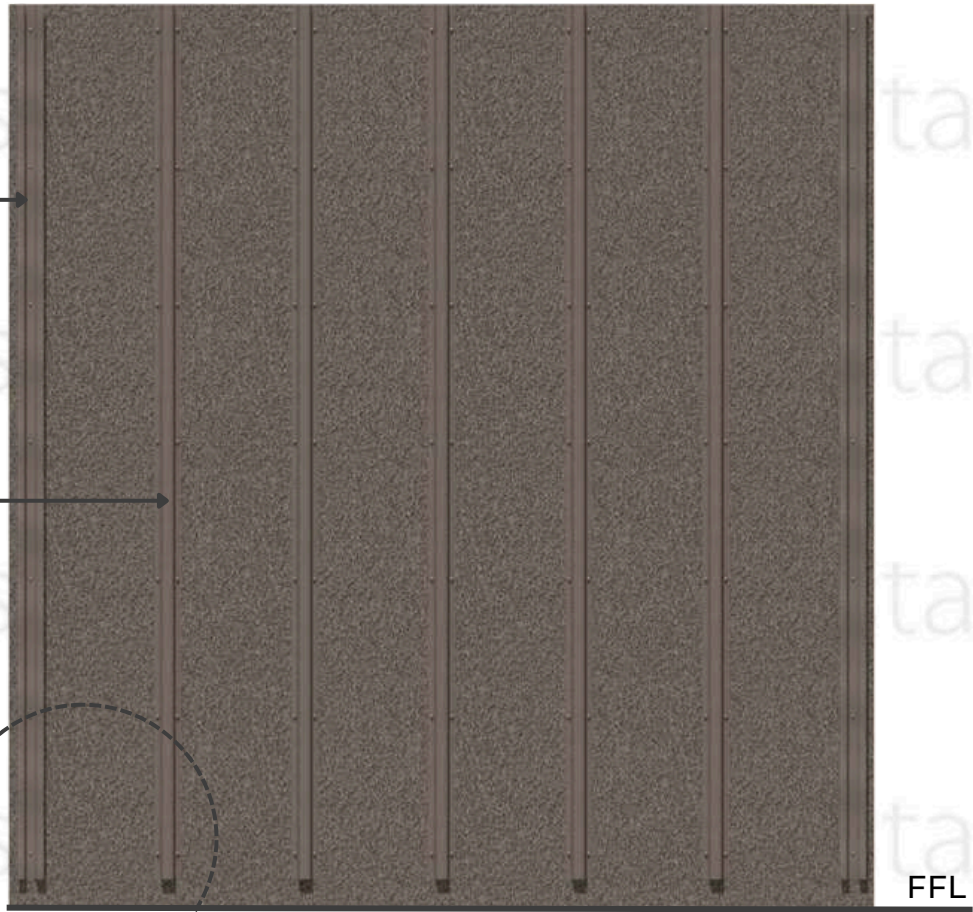

FRONT ELEVATION
Quik-Trim System

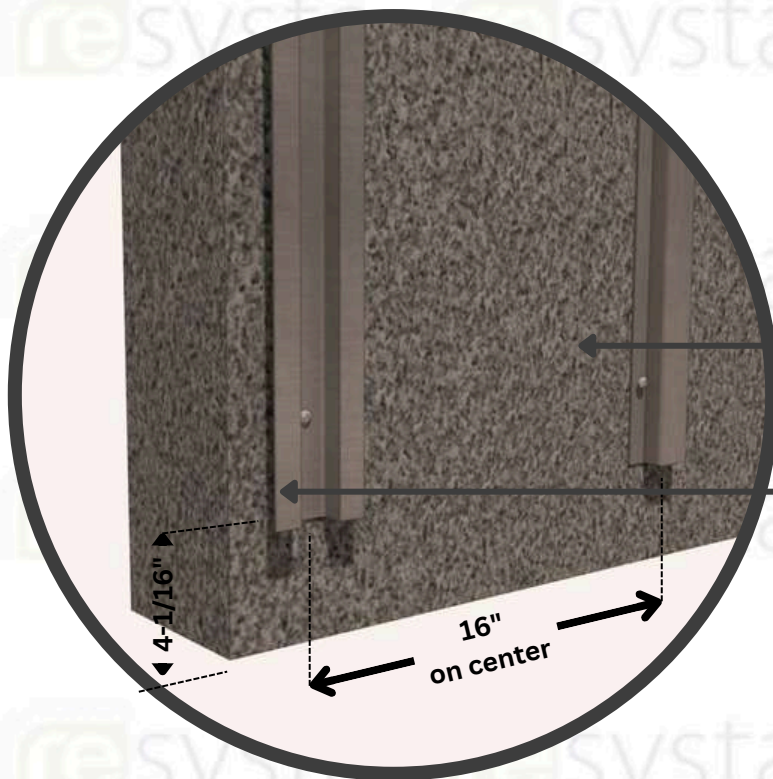

RESSHTC10
Siding Hat Channel

Reverse **RESSHTC10**
Siding Hat Channel

DETAIL
Quik-Trim System

Note:

For Vertical Rhombus Profile Installation a Perforated Hat Channel must be used to allow airflow and drainage of water.



16"
on center



FRONT ELEVATION
Quik-Trim System

Resysta rhombus board requires a minimum of 3" from the ground to the start of the rhombus board in both horizontal and vertical installations. Plan the batten substructure and wall assembly accordingly to accommodate siding installation while adhering with local building code requirements.

RESYSTA
Rhombus Profile

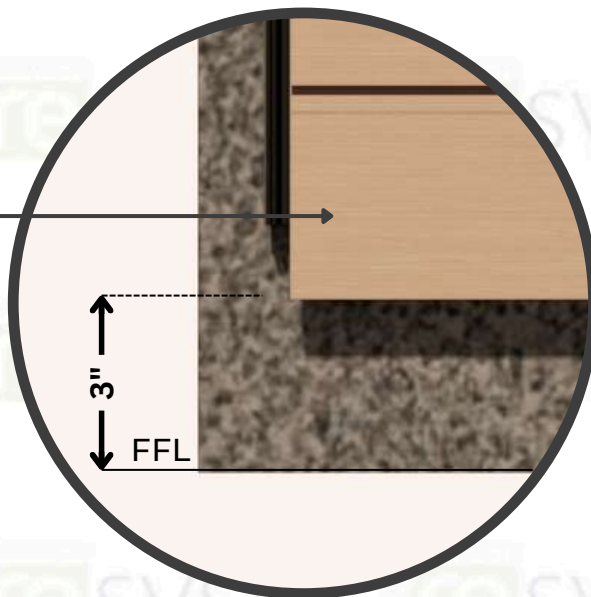

DETAIL
BATTEN DETAIL

Resysta Aluminum Batten Substructure

Install the battens and secure them to the frame substructure in compliance with local building codes. Ensure that the installed battens do not exceed the “Batten Spacing Requirements” of Table 1.2. On walls where two rhombus boards will be used end-to-end, a minimum of two battens must be used to accommodate the fastening of the rhombus board and any trim pieces desired to the batten substructure where the boards meet. Prior to installing the Resysta rhombus board, ensure that the batten installation provides a minimum $\frac{3}{4}$ ” air gap behind the rhombus board and there is sufficient support for all rhombus board and trim accessories. This is often achieved through the installation of battens with a minimum thickness of $\frac{3}{4}$ ”

Battens should be installed on top of a code-compliant sheathing with fasteners and fastener spacing sufficient to accommodate all loads imposed upon it by the Resysta rhombus board, trim components, and any other accessories attached to the battens. Resysta rhombus board must be attached to aluminum battens with Resysta Shoulder stainless steel screws (RESCPSS25 Screw) taking care to not penetrate the weather barrier. If the weather barrier is going to be penetrated reference the weather barrier manufacturer’s recommendations. Notes on Resysta Shoulder Screw RESCPSS25.

SECTION 2 - Trim and Accessory Options

Aluminum Rhombus Trim systems made for Resysta rhombus boards are recommended for covering the ends and gaps of rhombus boards. Suggested supply includes, but is not limited to: Quik-Trim Outside Corner Trim, Quik-Trim Inside Corner Trim, Starter J-Strip (to start siding boards), Quik-Trim H-Channel Trim (to cover wall gaps), Quik-Trim J-Channel Trim (used for board termination). Aluminum Quik-Trims are standard aluminum alloy 6063 T5 and have a .050” nominal wall thickness. Aluminum Trims come in 10’ lengths and shall have a standard Mill Finish for field priming and painting unless otherwise specified.

Aluminum Quik-Trim Rhombus Profile – General Installation Guidelines

Aluminum Quik-Trim Rhombus Trim must be cut with a 150-tooth carbide-tip blade for nonferrous metal. Blade Lubricant must be applied to the blade before each cut and the lubricant should be cleaned from the trim prior to installation. None of the rhombus trim should be installed horizontally unless weep holes are drilled at 8” intervals to allow for moisture to escape from behind the face flange. Exceptions to this are 1) a Starter J-Strip installed in any direction and 2) an Aluminum Quik-Trim is installed horizontally with its face flange pointing down.

Resysta Aluminum Quik-Trim Rhombus Profile – Aluminum Batten Installation Guidelines

When using metal battens, either steel or aluminum, it is recommended to use the shoulder SS Screw RESCPSS25 which can be driven through the aluminum trim and into the metal batten. The trim should be fastened 16” on the center for either horizontal or vertical installations. If the batten substructure spacing is reduced for the rhombus board the trim should be fastened at the same interval as the rhombus. Be aware of fastener placement for the trim to not hinder the installation of the Resysta rhombus board.

SECTION 3 – Horizontal Rhombus Profile Applications

STEP 3.1

Pre-apply the Quik-Trim PVC base for all finishing trim accessories such as trim around corners, windows, and doors according to the pre-plan layout and following the manufacturer’s recommendations. Ensure that all trim is level and square. Battens should be installed vertically.

STEP 3.2

An aluminum starter strip is required to install the Resysta rhombus board. Attach the starter J-strip at the bottom of the battens following the fastener and spacing recommendations in Section 2. The Resysta rhombus boards will hang below the bottom of the starter strip therefore the starter strip should be attached accordingly as per the pre-plan layout.

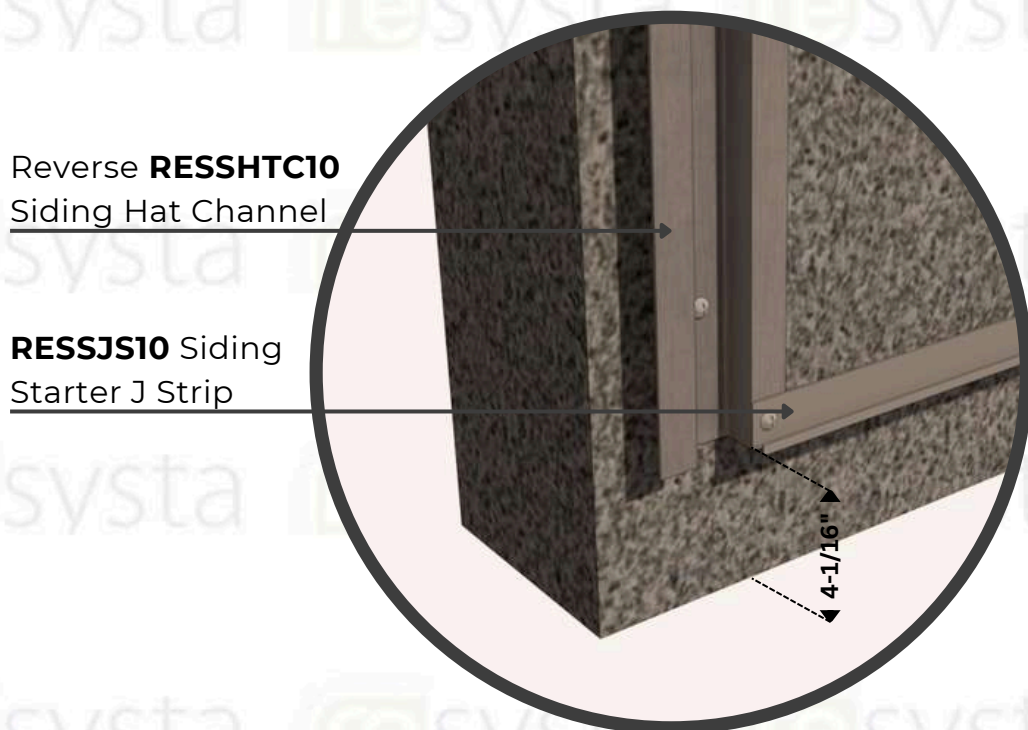

DETAIL

Quik-Trim System

STEP 3.3

The Quik-Trim PVC base should be installed at every end of the reverse hat channel and on top of all the hat channels, by screwing on the PVC base on its groove.



Reverse **RESHTC10**
Siding Hat Channel

Quik-Trim
PVC base

DETAIL

Quik-Trim System



FRONT ELEVATION
Quik-Trim System

STEP 3.4

Hook the groove end of the first rhombus board into the starter J strip.



Quik-Trim
PVC base

RESYSTA
Stater J-Strip

RESYSTA
Rhombus Profile



FRONT ELEVATION
Quik-Trim System

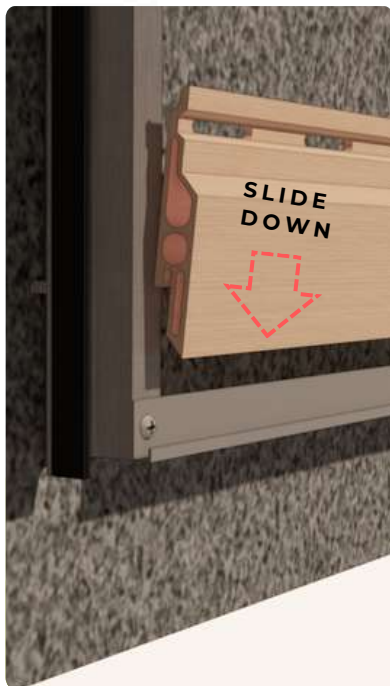

DETAIL 1

Slide down the first Resysta Rhombus board into starter J-strip.

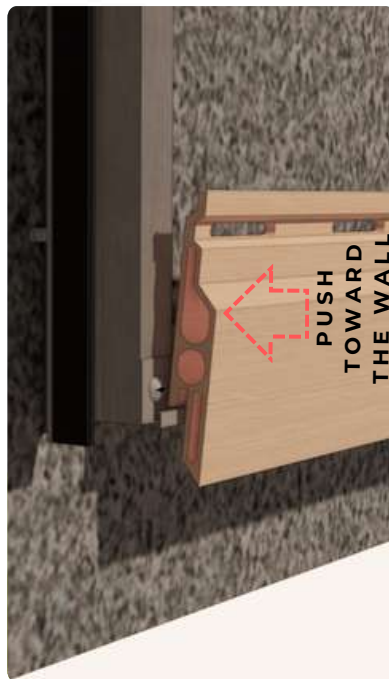

DETAIL 2

Hook the groove end of the first Resysta Rhombus board into the starter J-strip with SS screw.

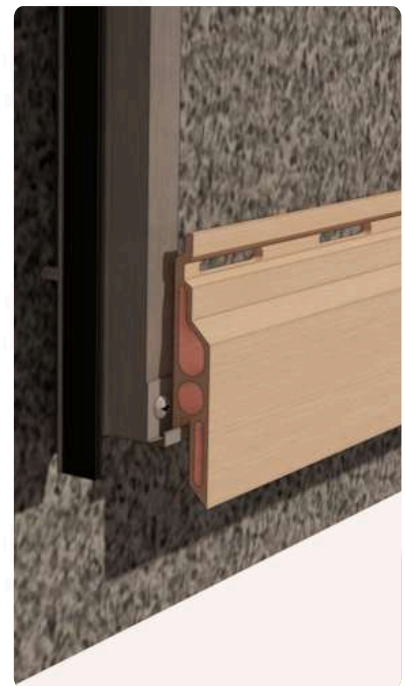

DETAIL 3

Push the Resysta Rhombus board perpendicular into the runner and screw direct to the groove.

STEP 3.5

Install the shoulder SS screws RESCPSS25 into all slotted holes except the center hole. DO NOT over-tighten the screws. The screws should be placed in the center of the slotted hole and loose enough to allow the board to move freely from side to side to allow for expansion and contraction.

RESSHTC10

Siding Hat Channel

RESCPSS25

Shoulder SS Screw

RESYSTA

Rhombus Profile

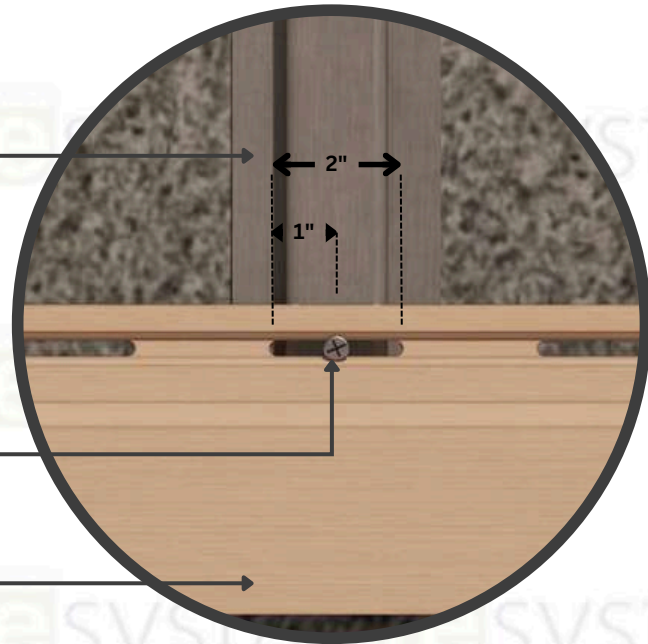

DETAIL

Quik-Trim System

No Screw

RESCPSS25

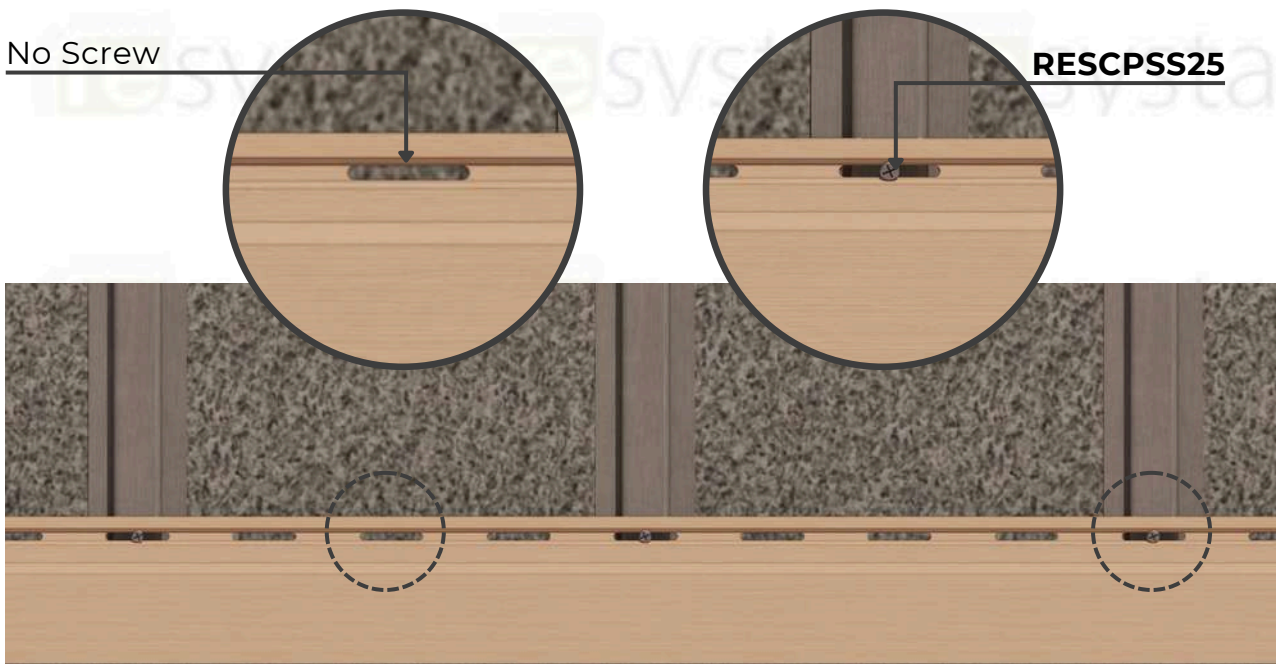

FRONT ELEVATION

Quik-Trim System

Note

If installing more than one board in width, please refer to Section 4 – Horizontal Multi Board Rhombus Profile Applications

STEP 3.6

Install the final two RESCPSS25 screws in the slotted hole in the center of the board. This will allow for expansion and contraction evenly to each side of the assembly. Check the instruction pinning location in Section 8.

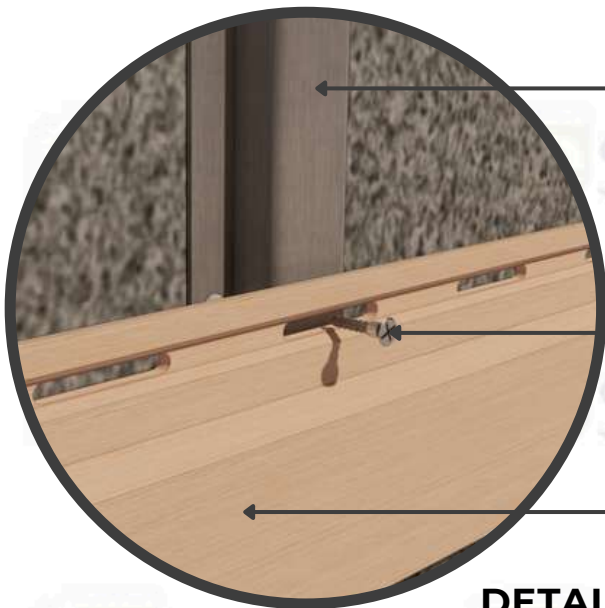

RESSHTC10
Siding Hat Channel

RESCPSS25
Shoulder SS Screw

RESYSTA
Rhombus Profile

DETAIL
Quik-Trim System

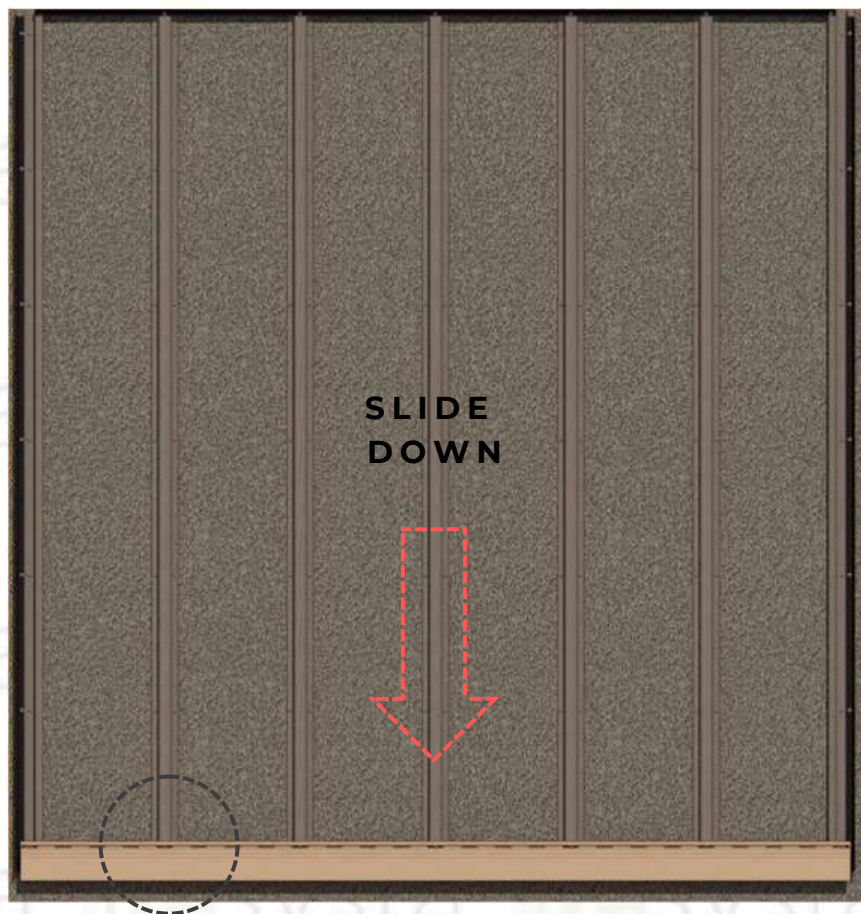

FRONT ELEVATION
Quik-Trim System

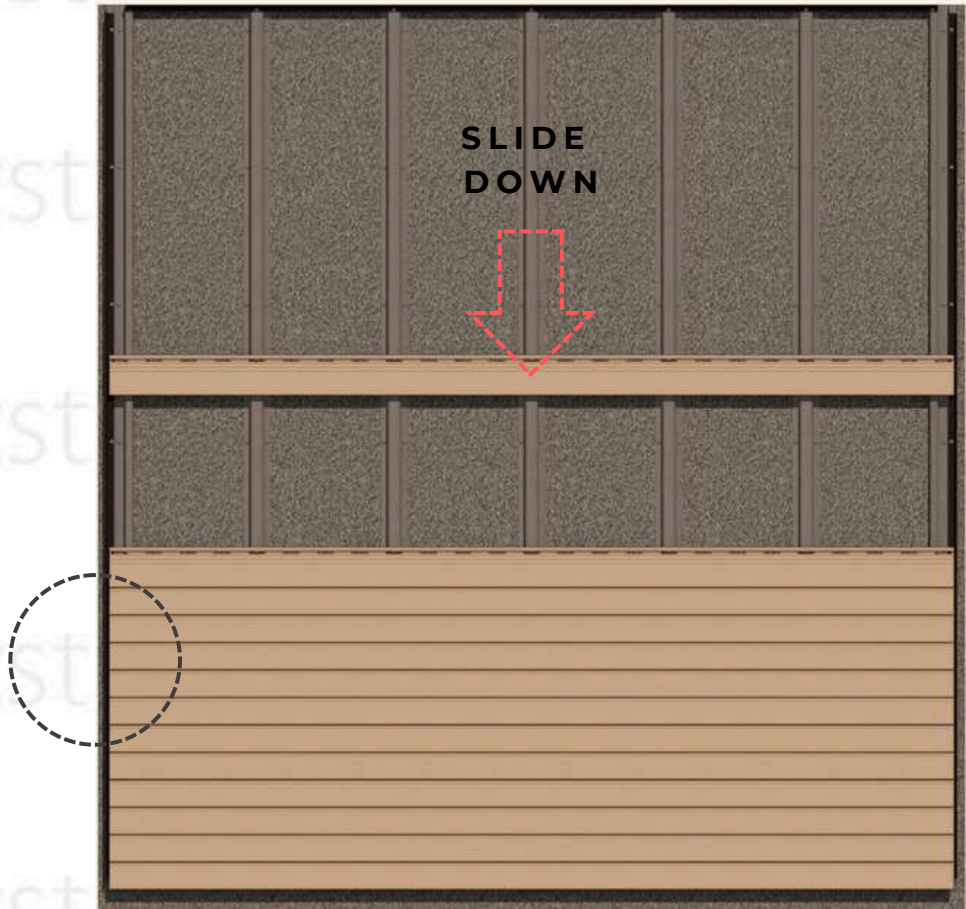
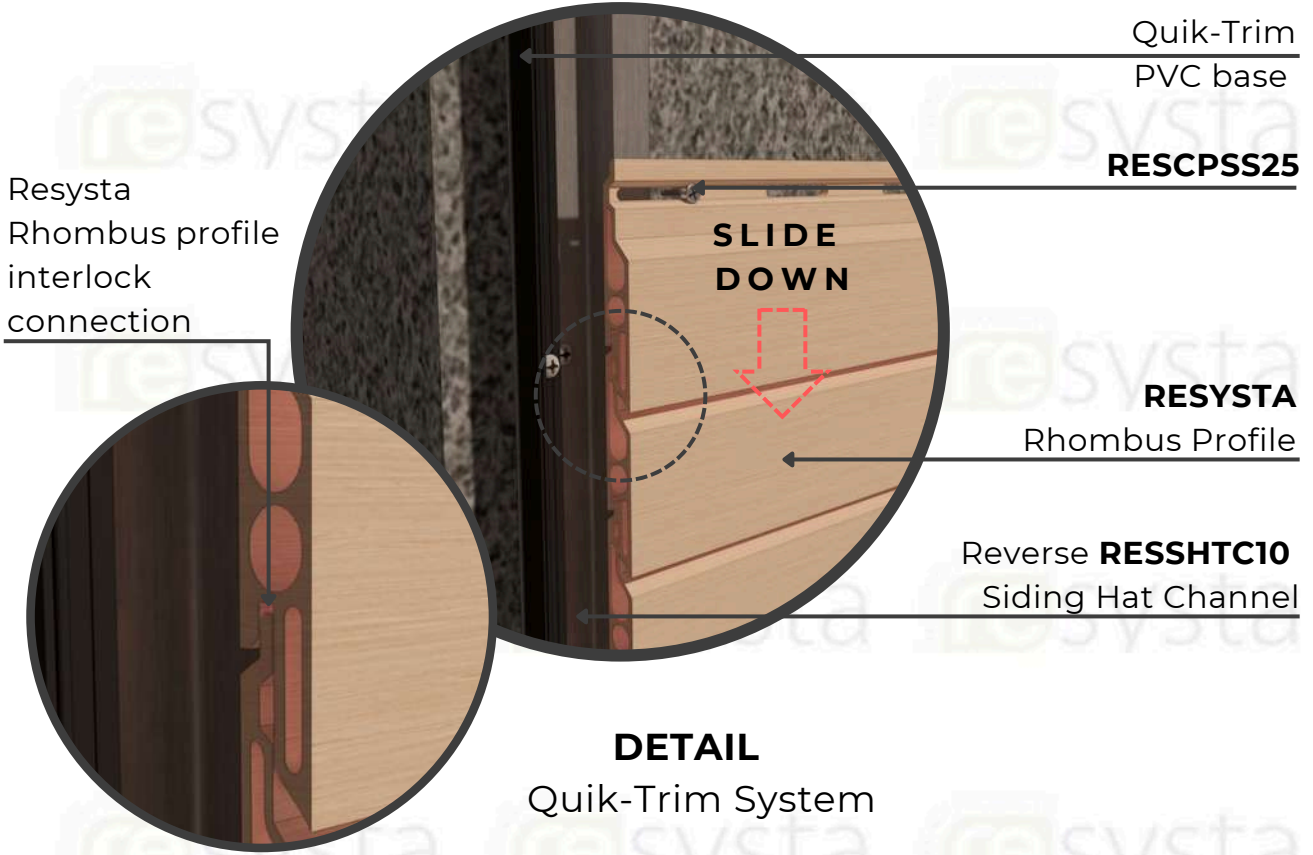

STEP 3.7

Hook the groove end of the next board onto the tongue of the installed rhombus board.

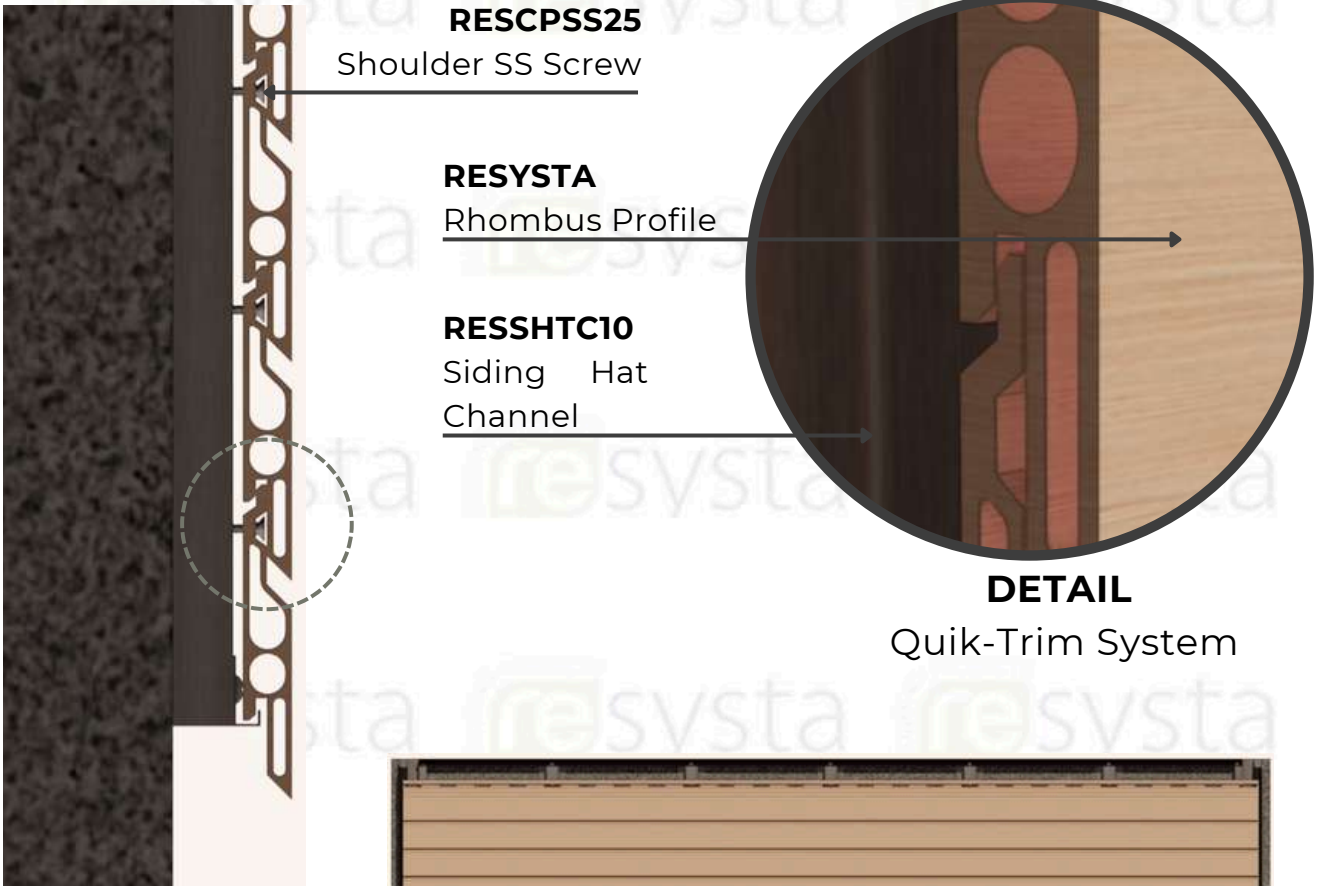

SECTION
Quik-Trim System



DETAIL
Quik-Trim System



FRONT ELEVATION
Quik-Trim System

STEP 3.8

Continue installing the rhombus board as outlined in Section 3. Rip the last rhombus board into size to complete.

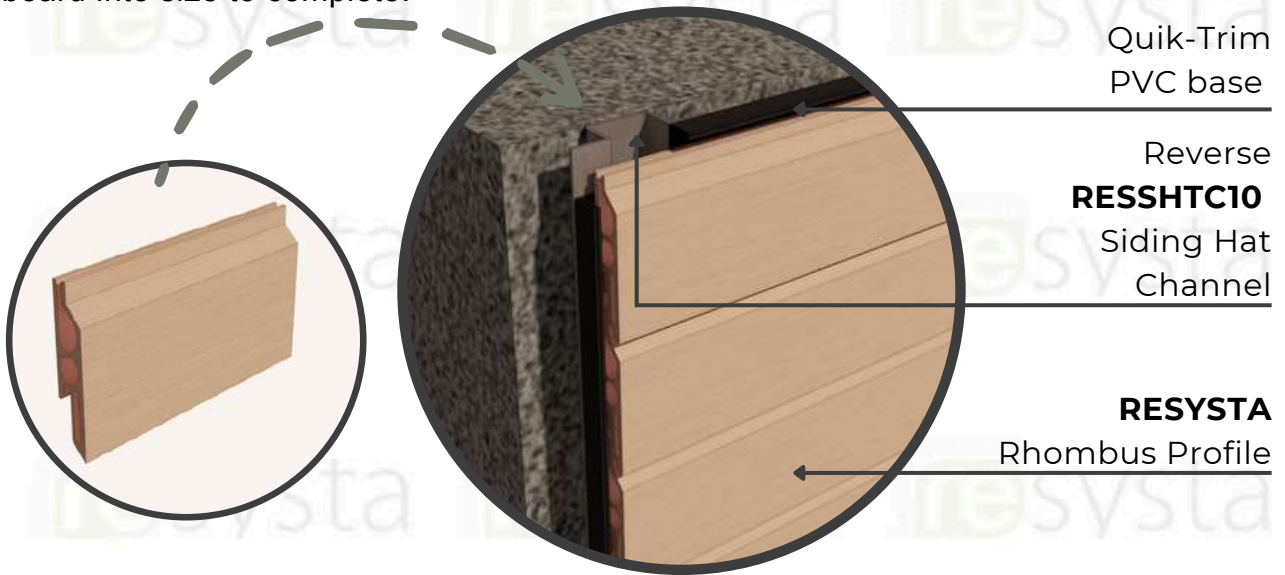

DETAIL

Quik-Trim System



Rip the
tongue part

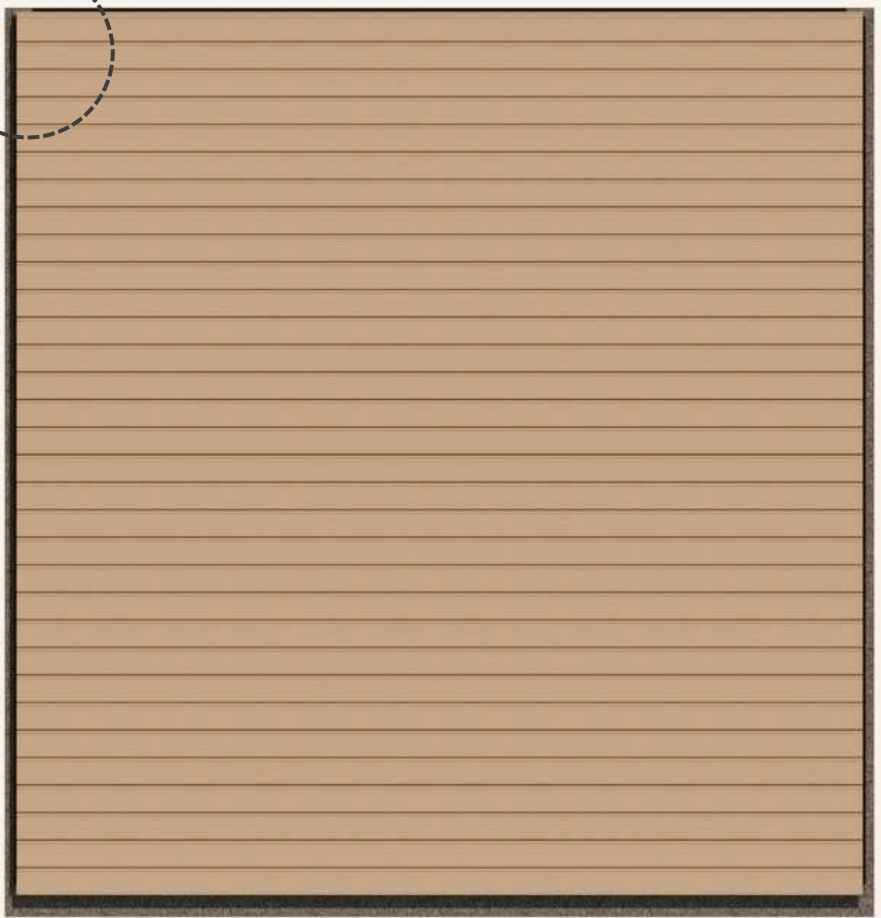
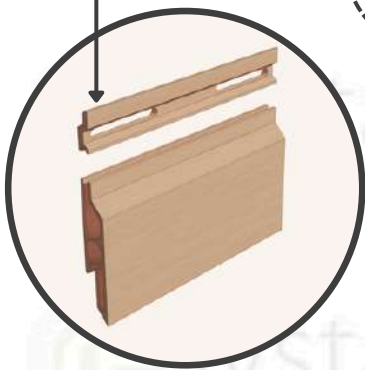

FRONT ELEVATION
Quik-Trim System

STEP 3.9

After the installation of the last rhombus board, the exposed rhombus board edges will be finished by installing the aluminum Quik-Trim. Finally, install the window J-mold into the PVC base on the sides and the J-mold into the topmost part.

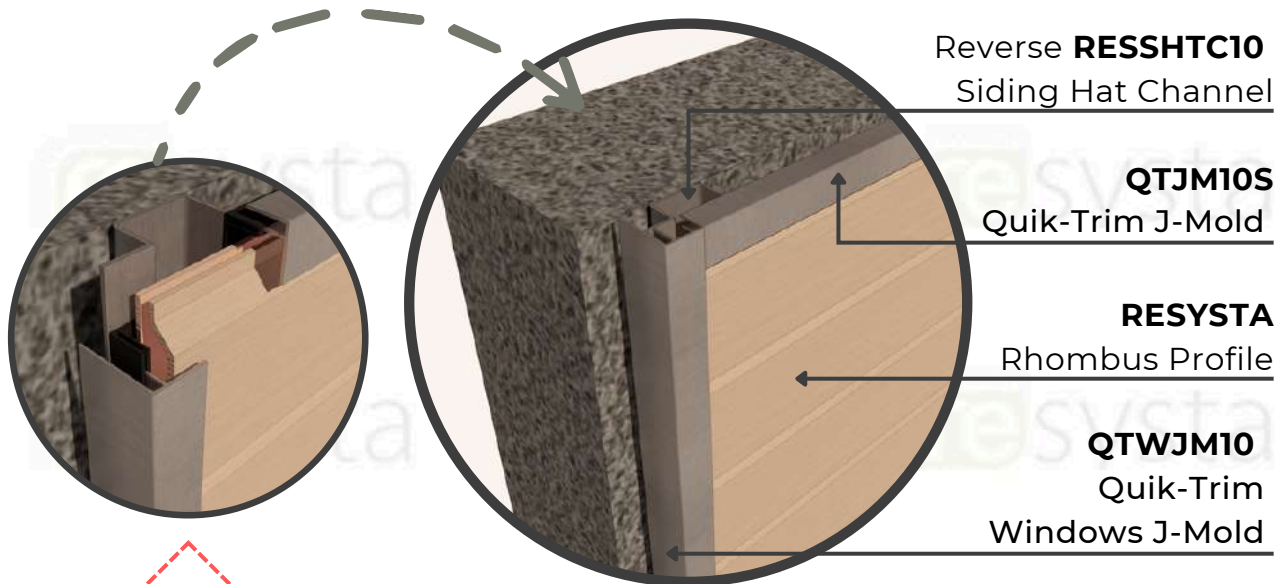

DETAIL
Quik-Trim System

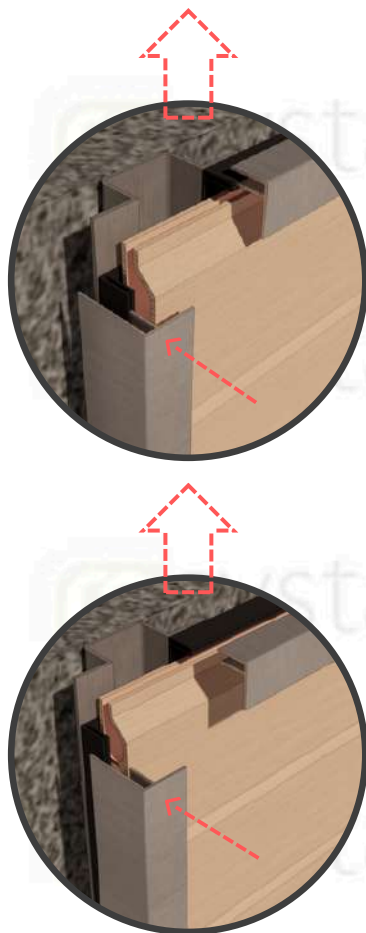

Install the
window J-mold
into the PVC base

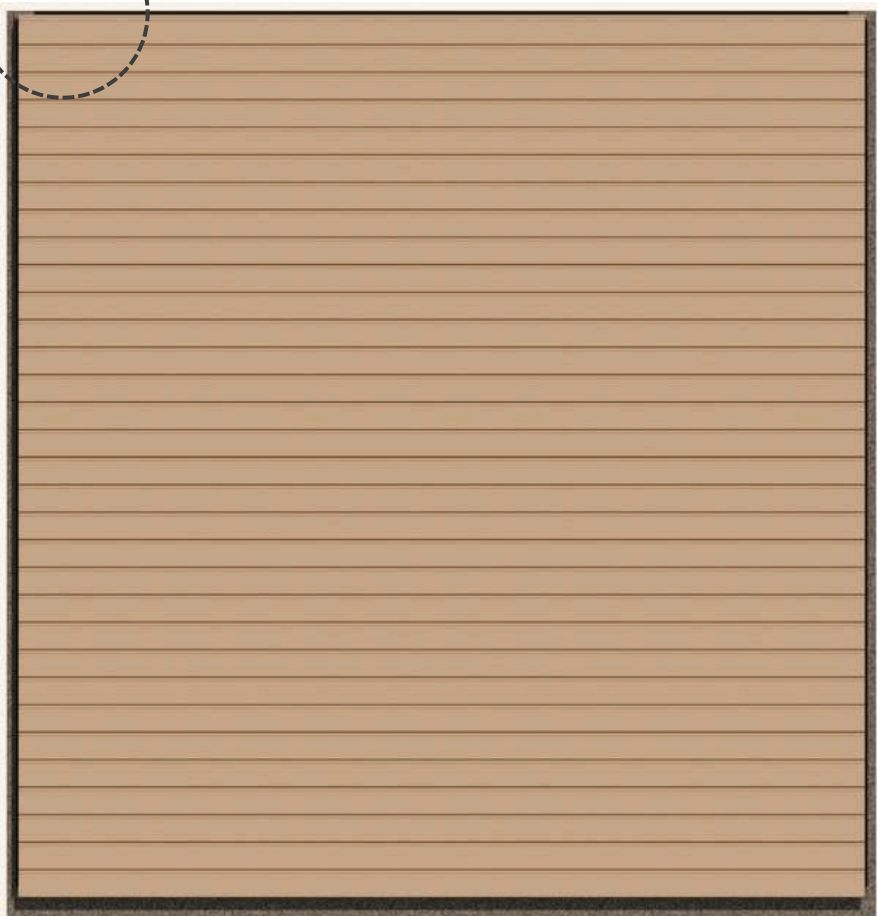

FRONT ELEVATION
Quik-Trim System

SECTION 4 – Multi-Board Horizontal Rhombus Profile

Applications

2 Board Wide Installation without the Aluminum Quik-Trim H-mold (24ft max width)

STEP 4.1.1

Ensure that two battens have been installed where boards are to be installed end to end.

STEP 4.1.2

Follow Steps 3.1, 3.2, and 3.3 from Section 3 to install the finishing trim, starter J-strip, and hook in the 1st board.

STEP 4.1.3

Install RESCPSS25 screws into all slotted holes except the hole closest to the abutted joint on both boards. DO NOT over-tighten the screws. The screws should be placed in the center of the slotted hole and loose enough to allow the board to move freely from side to side to allow for expansion and contraction.

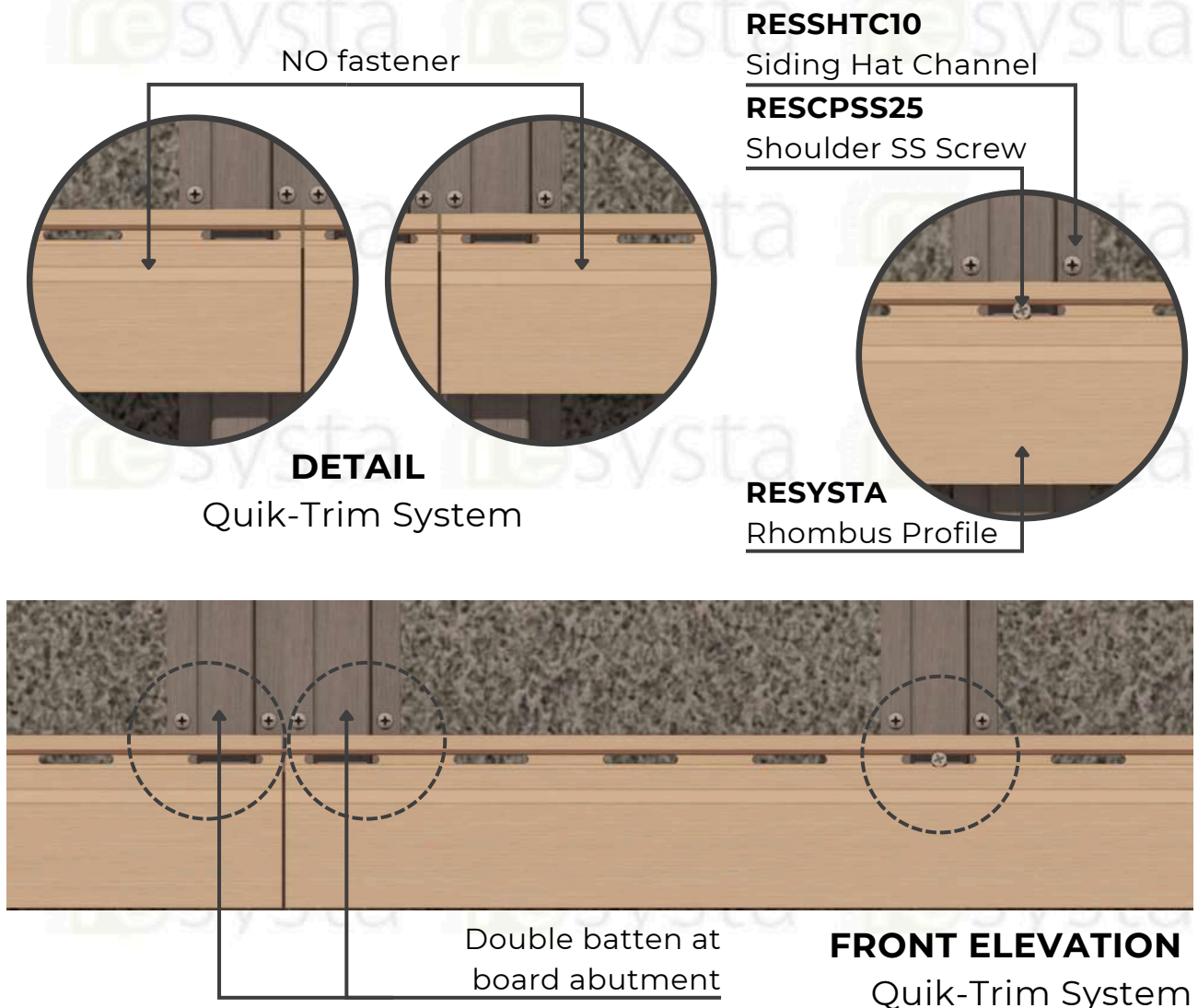

STEP 4.1.4

Install one RESCPSS25 screw in the slotted hole closest to the abutted joint on both rhombus boards. This will control expansion and contraction evenly to the outside of the rhombus board while keeping the abutting joint snug.

RESCPSS25

Shoulder SS Screw

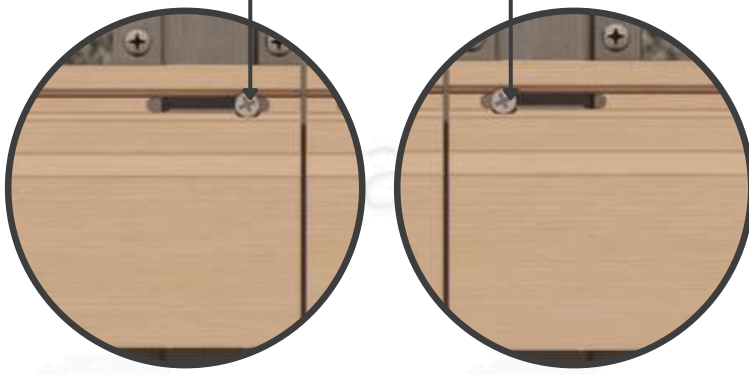

DETAIL
Quik-Trim System

RESSHTC10

Siding Hat Channel

RESCPSS25

Shoulder SS Screw

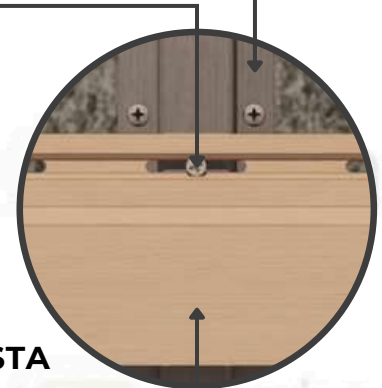

RESYSTA

Rhombus Profile

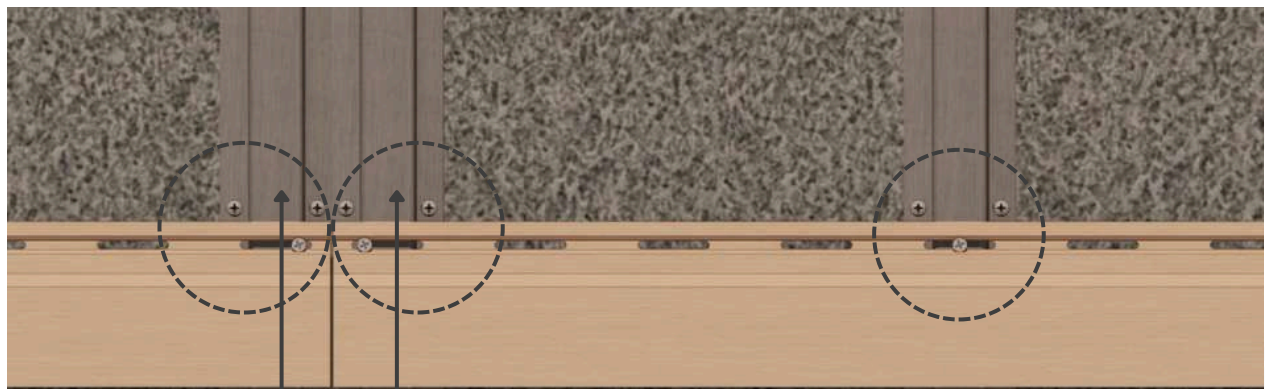

Double batten at
board abutment

FRONT ELEVATION
Quik-Trim System

STEP 4.1.5

Hook the groove end of the next board onto the tongue of the installed rhombus board.

STEP 4.1.6

Continue installing the rhombus board as outlined in Section 4: "2 Board Wide Installation without the Aluminum Quik-Trim H-mold" and follow steps 3.8 and 3.9 in Section 3 to finish the installation.

Multi-Board Wide Installation using Continuous Aluminum Quik-Trim H-mold

STEP 4.2.1

Follow Steps 3.1, 3.2 and 3.3 from Section 3.

STEP 4.2.2

Install the Quik-Trim PVC base into the hat channel where the aluminum Quik-Trim H-mold will be installed.



Quik-Trim
PVC base

RESSHTC10
Siding Hat Channel

DETAIL

Quik-Trim System

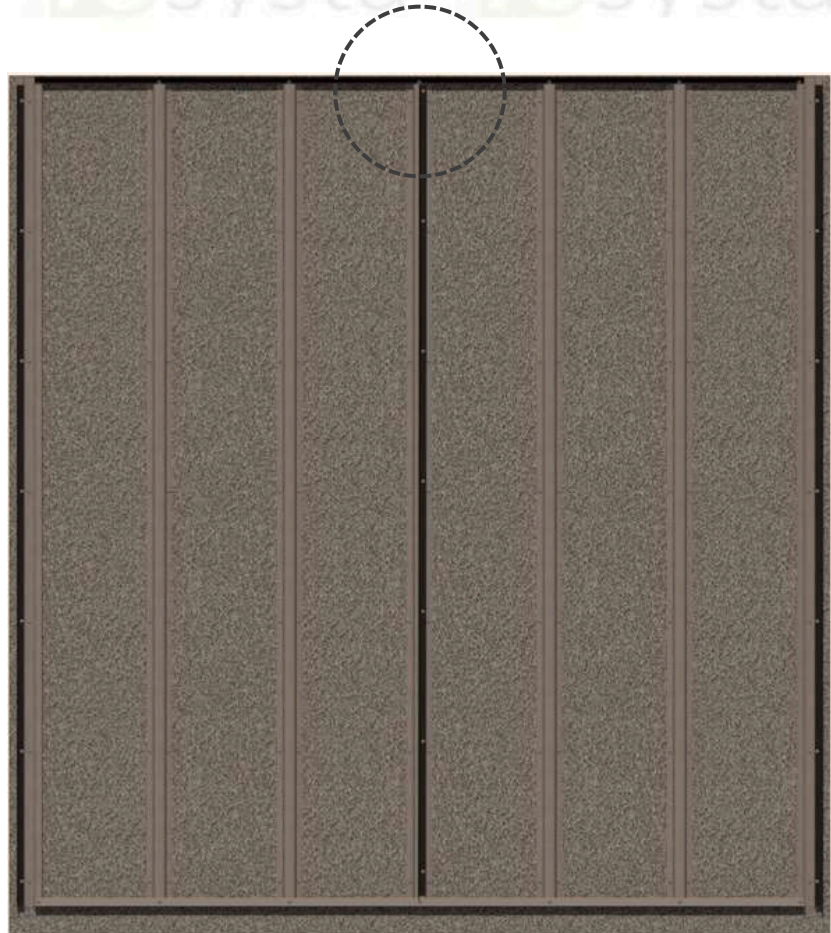

FRONT ELEVATION

Quik-Trim System

STEP 4.2.3

Follow steps 3.4, 3.5, and 3.6 of Section 3 and install RESCPSS25 screws or #8 screws into all slotted holes except the center hole. DO NOT over-tighten the screws. The screws should be placed in the center of the slotted hole and loose enough to allow the board to move freely from side to side to allow for expansion and contraction.

RESSHTC10

Siding Hat Channel

RESCPSS25

Shoulder SS Screw

RESYSTA

Rhombus Profile

Quik-Trim PVC base

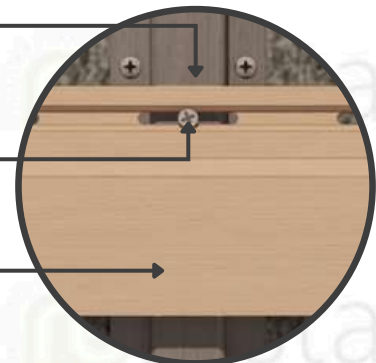

DETAIL



FRONT ELEVATION

Quik-Trim System

STEP 4.2.4

Install the final two RESCPSS25 screws closest to the ends in the slotted hole in the center of the board. This will allow for expansion and contraction evenly to each side of the assembly.



DETAIL

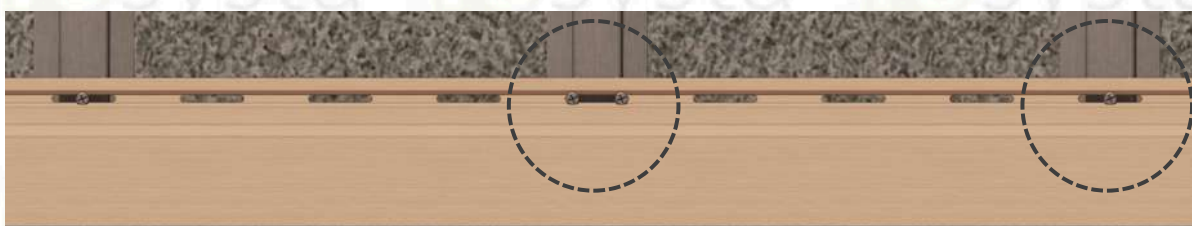

FRONT ELEVATION

Quik-Trim System



RESSHTC10
Siding Hat Channel

Quik-Trim
PVC base

RESYSTA
Rhombus Profile

DETAIL

Quik-Trim System

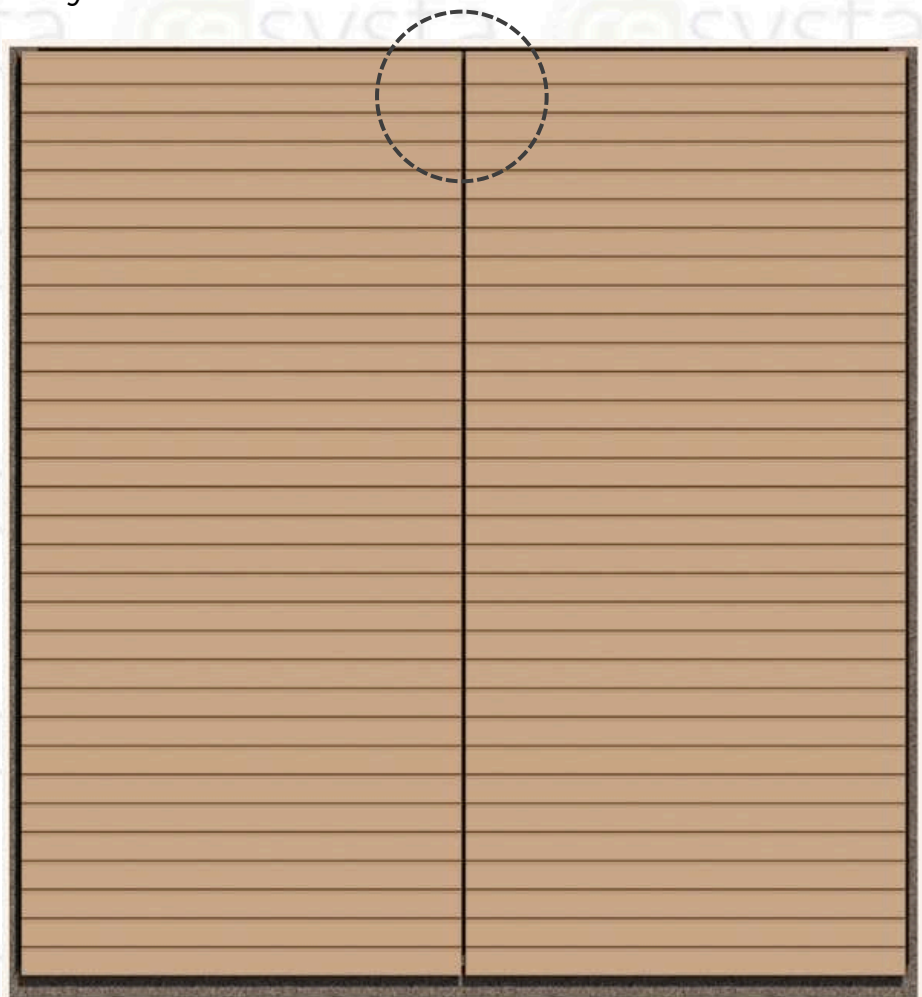

FRONT ELEVATION
Quik-Trim System

STEP 4.2.5

After the installation of the last rhombus board, finally, install all the aluminum trim on the PVC base to finish the installation.

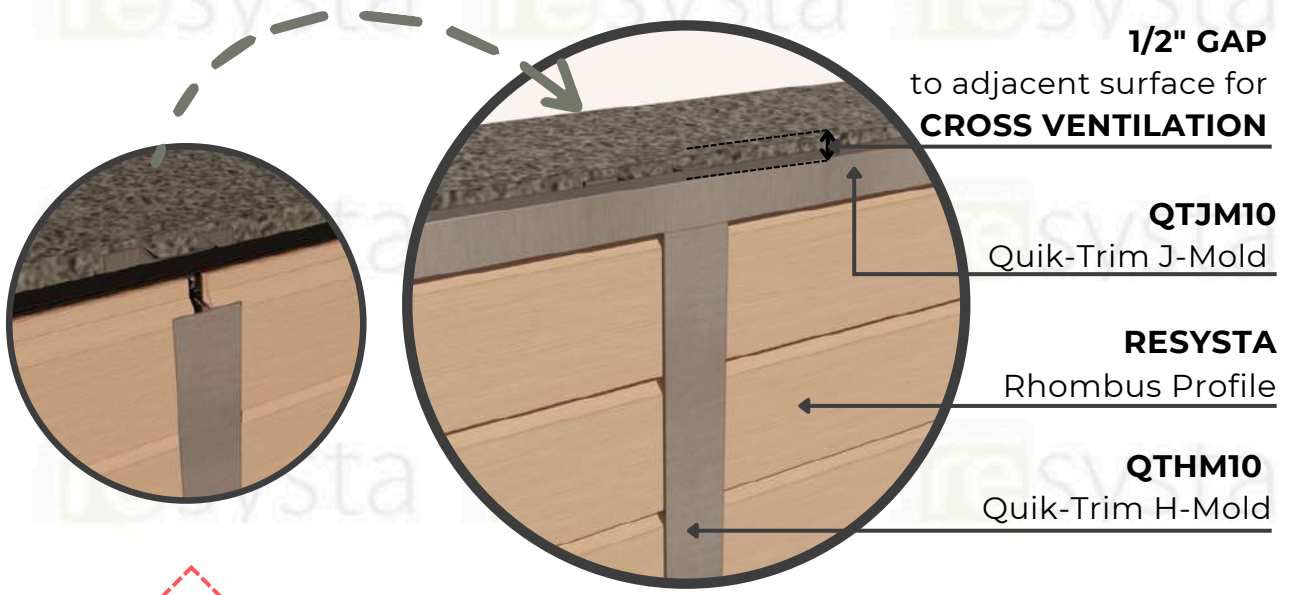

DETAIL

Quik-Trim System

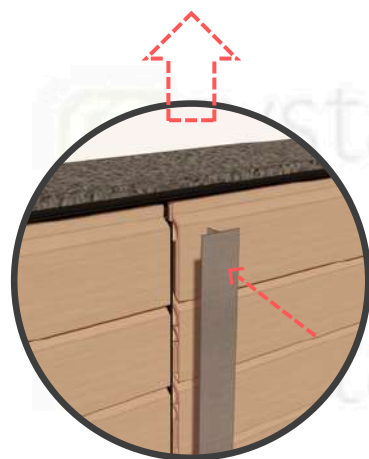
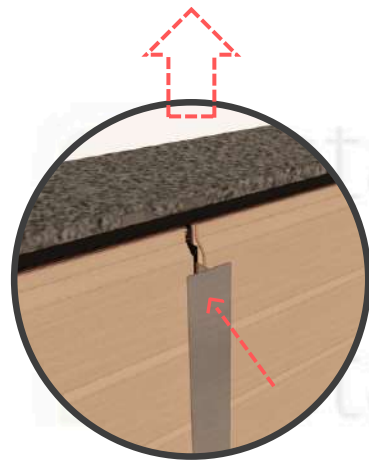

Install the
H-mold into the
PVC base

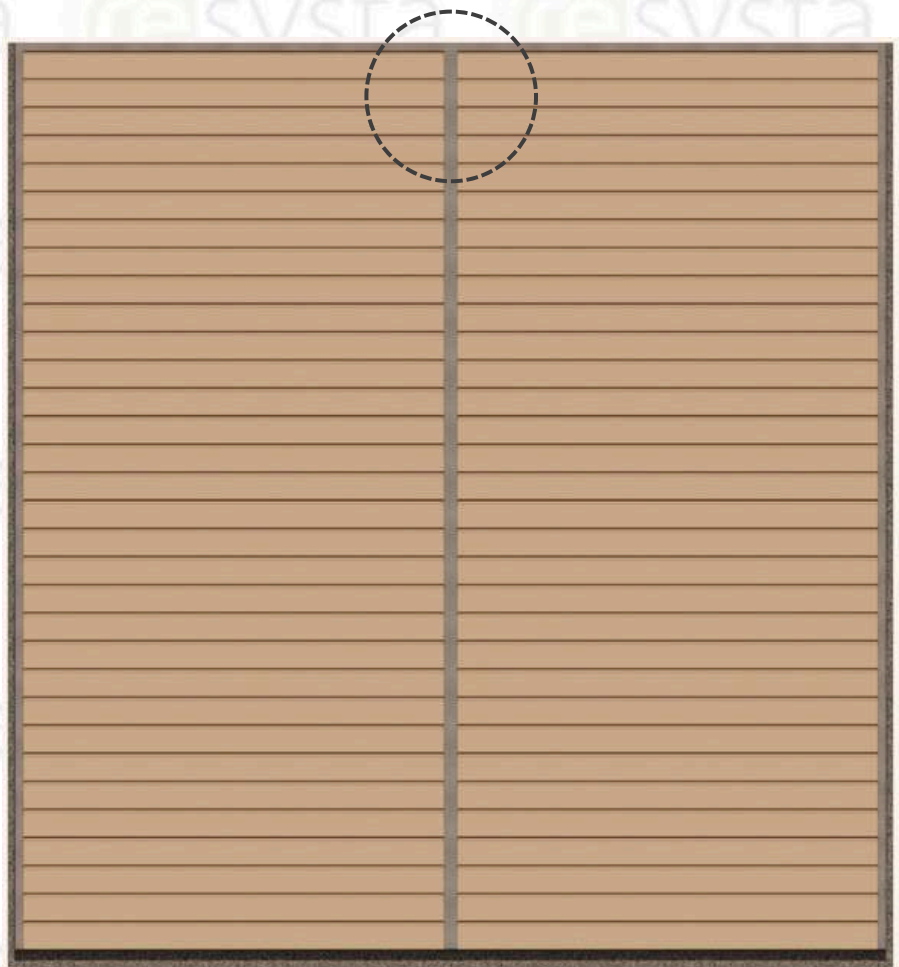

FRONT ELEVATION

Quik-Trim System

SECTION 5 – Vertical Rhombus Profile Applications

STEP 5.1

Pre-apply the Quik-Trim PVC base for all finishing trim accessories such as trim around corners, windows, and doors according to the pre-plan layout and following the manufacturer's recommendations. Ensure that all trim is level and square. Battens should be installed horizontally with punched holes.

STEP 5.2

A starter J-strip is required to install the Resysta rhombus board. Attach the starter J-strip vertically at one end of the batten substructure following the fastener and spacing recommendations in Section 2. The Resysta rhombus board will hang ½" beyond the starter J-strip therefore the starter strip should be attached accordingly per the pre-plan layout. If the rhombus profile is starting in a corner the corner attachment and the starter J-strip should be attached at the same time.

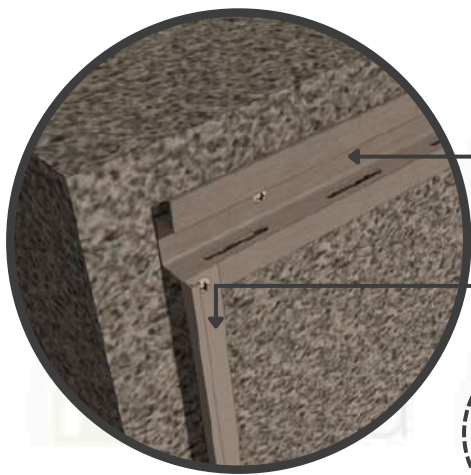

Reverse **RESSHTC10P**
Siding Hat Channel with
punched hole

RESSJS10 Siding
Starter J Strip

DETAIL
Quik-Trim System



FRONT ELEVATION
Quik-Trim System

STEP 5.3

The Quik-Trim PVC base should be installed at every end of the reverse hat channel and on side of all the hat channels, by screwing on the PVC base on its groove.

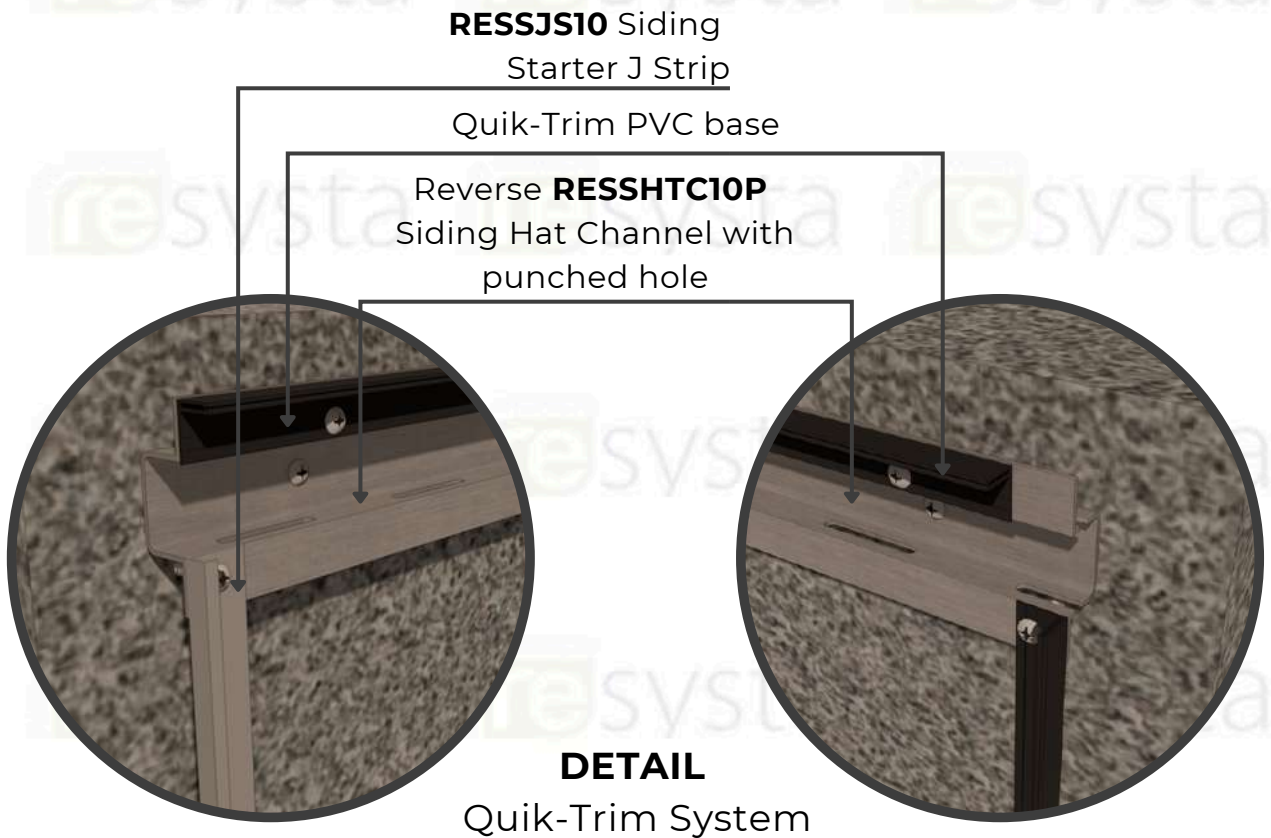

FRONT ELEVATION
Quik-Trim System

STEP 5.4

Hook the groove end of the first rhombus board into the starter J-strip vertically.

Reverse **RESSHTC10P**
Siding Hat Channel with
punched hole

RESSJS10 Siding
Starter J Strip

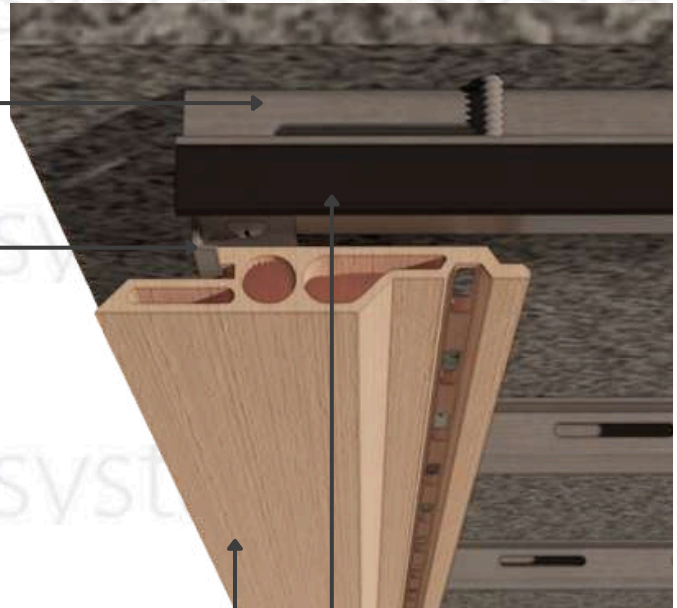
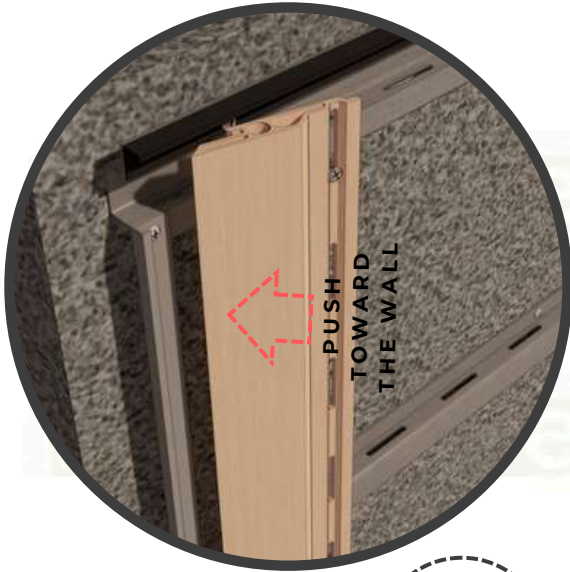

Quik-Trim
PVC base

RESYSTA
Rhombus Profile

DETAIL
Quik-Trim System



FRONT ELEVATION
Quik-Trim System

STEP 5.5

Continuously install the rhombus board vertically and install a RESCPSS25 screw or a #8 screw into the slotted hole at the top of the rhombus board. DO NOT over-tighten this screw. This screw should be placed at the top of the slotted hole and loose enough to allow the board to move freely in the vertical direction allowing for expansion and contraction.

RESYSTA

Rhombus Profile

RESCPSS25

Shoulder SS Screw

RESSHTC10P

Siding Hat Channel with punched hole

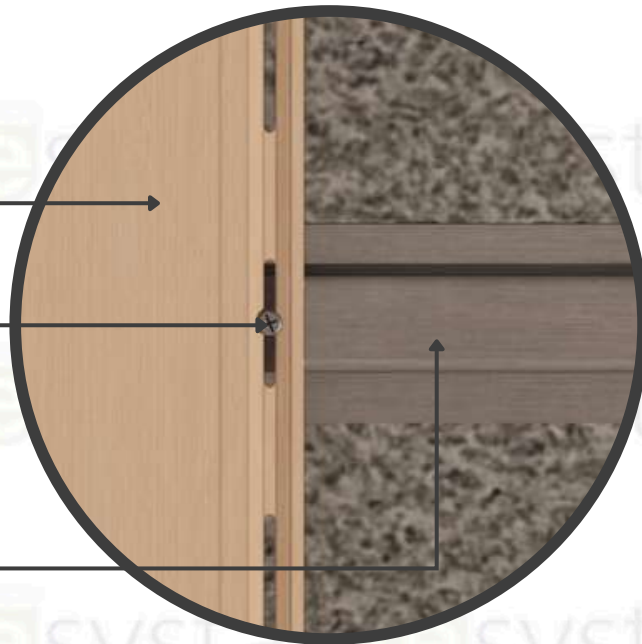

DETAIL

Quik-Trim System

RESSHTC10P

Siding Hat Channel with punched hole

RESCPSS25

Shoulder SS Screw

RESYSTA

Rhombus Profile

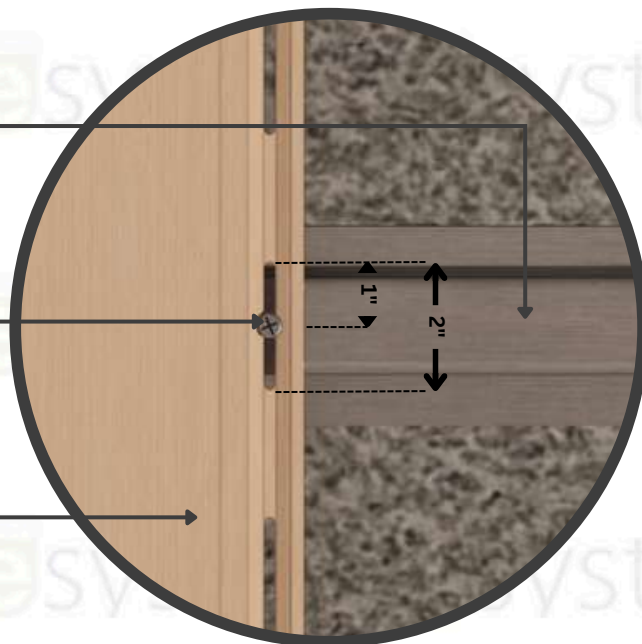

DETAIL

Quik-Trim System

Special Requirement

By following these installation guides for vertical installation methods ALL expansion and contraction will happen at the bottom of the board. Gap the bottom of the board properly based on installation needs.

Note

If installing more than one board in height, please refer to Section 6 – Vertical Multi-Board Rhombus Profile Applications

STEP 5.6

Continue installing the rhombus board vertically as outlined in Section 5 until the last rhombus board is installed.

RESYSTA

Rhombus Profile

Reverse **RESSHTC10P**

Siding Hat Channel with punched hole

Quik-Trim

PVC base



DETAIL

Quik-Trim System

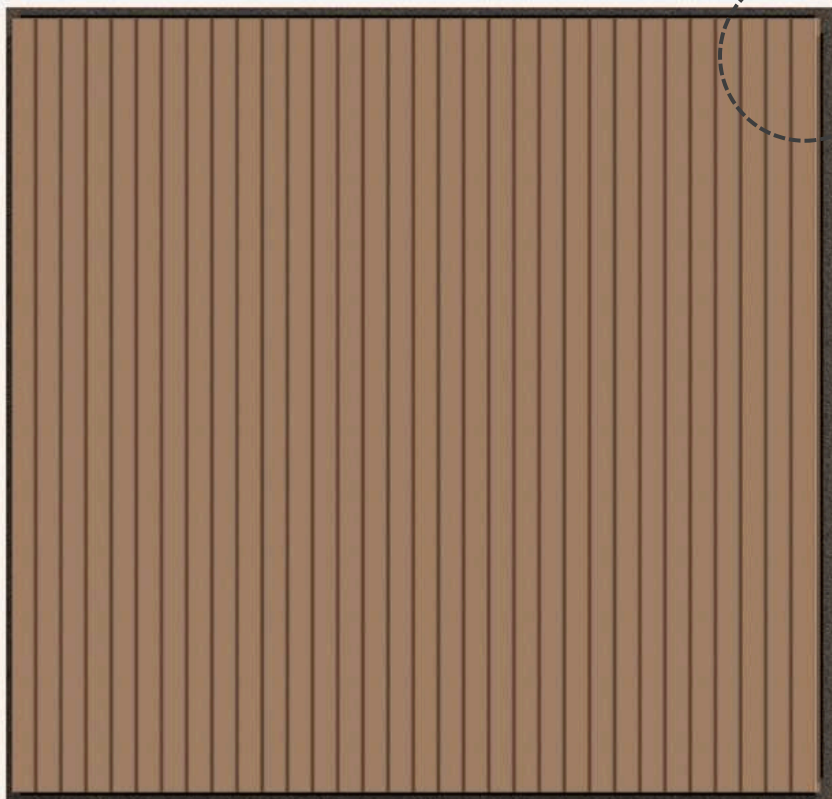

FRONT ELEVATION

Quik-Trim System

STEP 5.7

After the installation of the last vertical rhombus board, finally, install all the aluminum trim on the PVC base to finish the installation.

1/2" GAP

to adjacent surface for
CROSS VENTILATION

RESYSTA

Rhombus Profile

QTWJM10

Quik-Trim

Windows J-Mold



DETAIL

Quik-Trim System

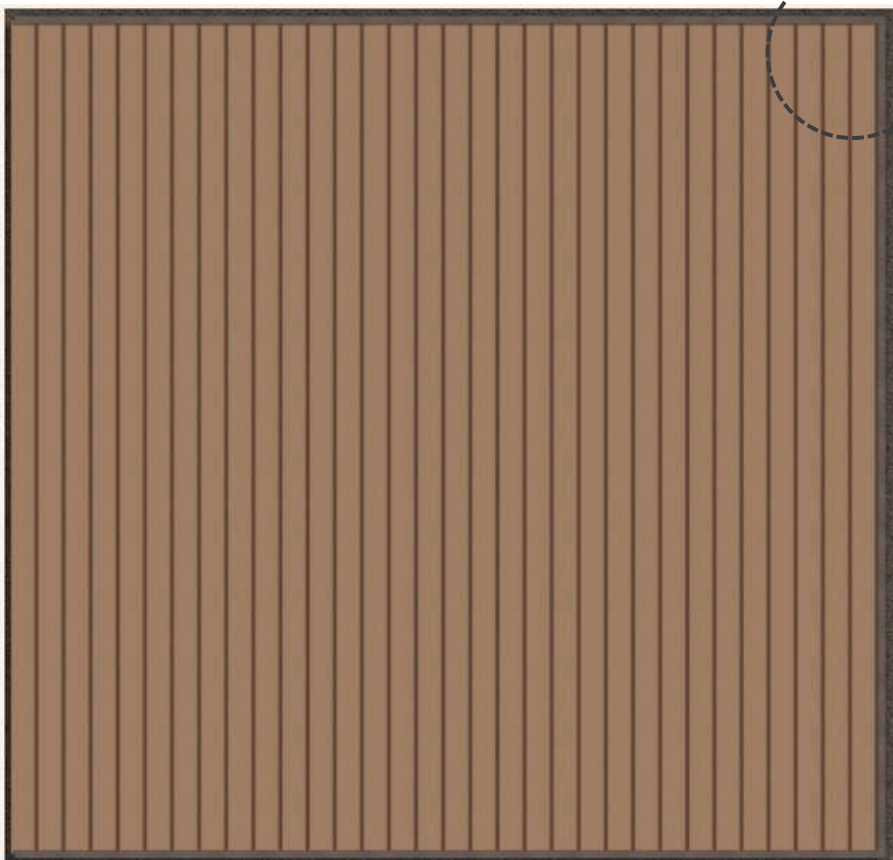

FRONT ELEVATION

Quik-Trim System

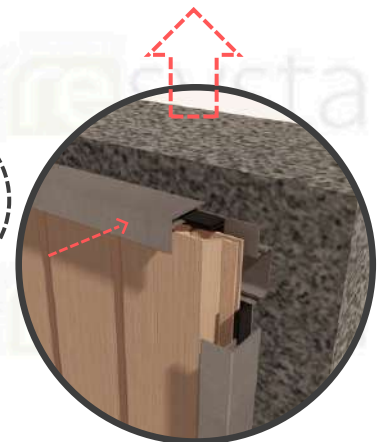

Install the window
J-mold into the PVC
base

SECTION 6 – Multi-Board Vertical Rhombus Profile Applications

2 Board High Installation without the Aluminum Quik-Trim H-mold (24ft max width)

STEPS 6.1.1

Ensure that two battens have been installed horizontally where boards are to be installed end to end.

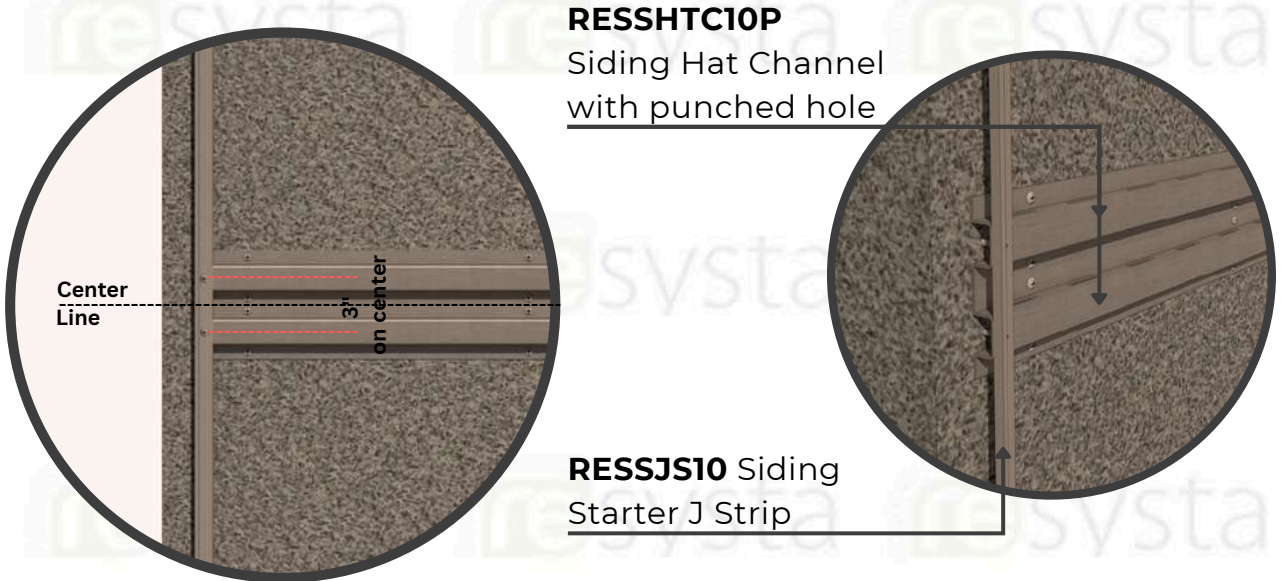

DETAIL Quik-Trim System



FRONT ELEVATION
Quik-Trim System

STEP 6.1.2

The Quik-Trim PVC base should be installed at every end of the reverse hat channel and on side of all the hat channels, by screwing on the PVC base on its groove.

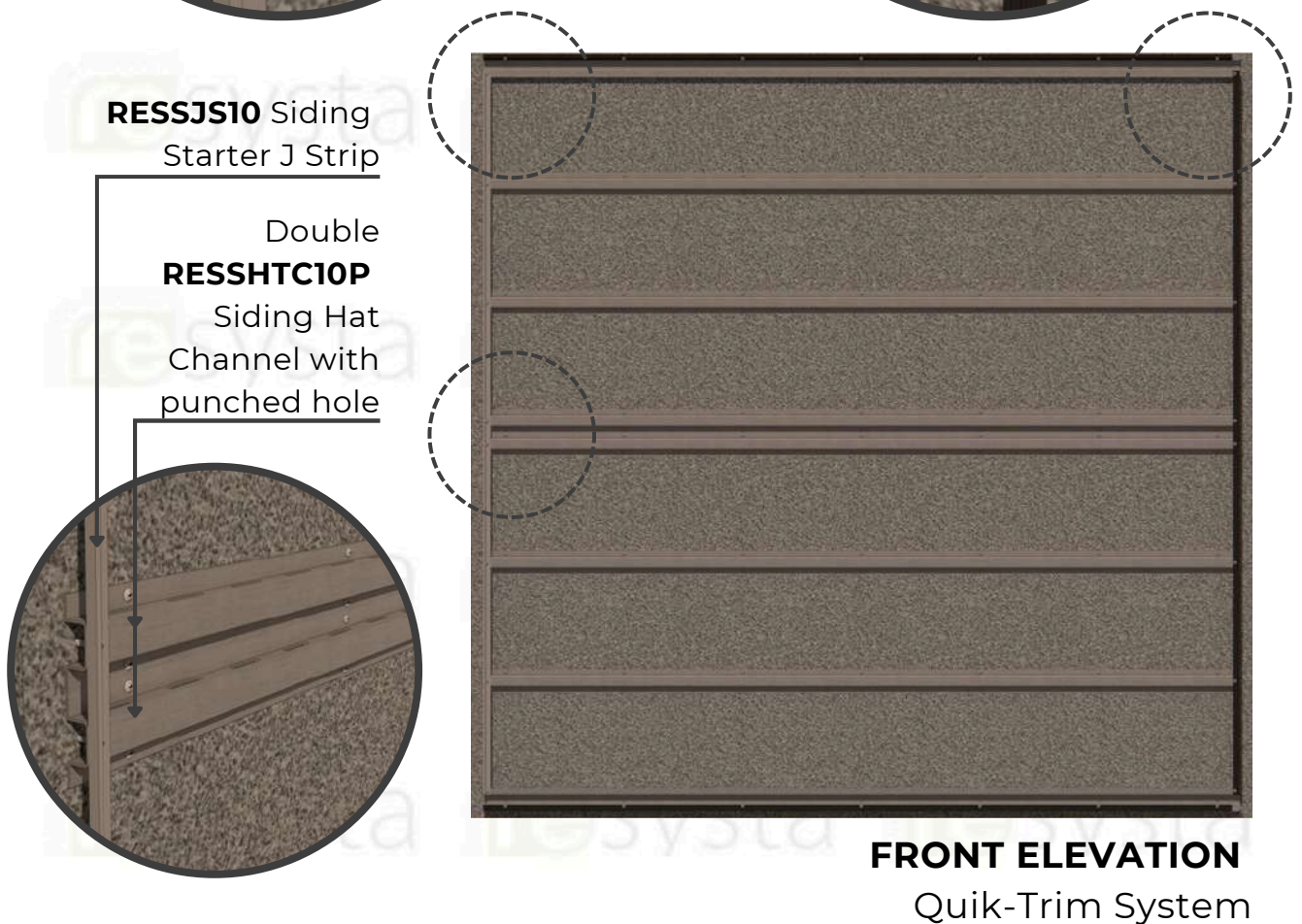
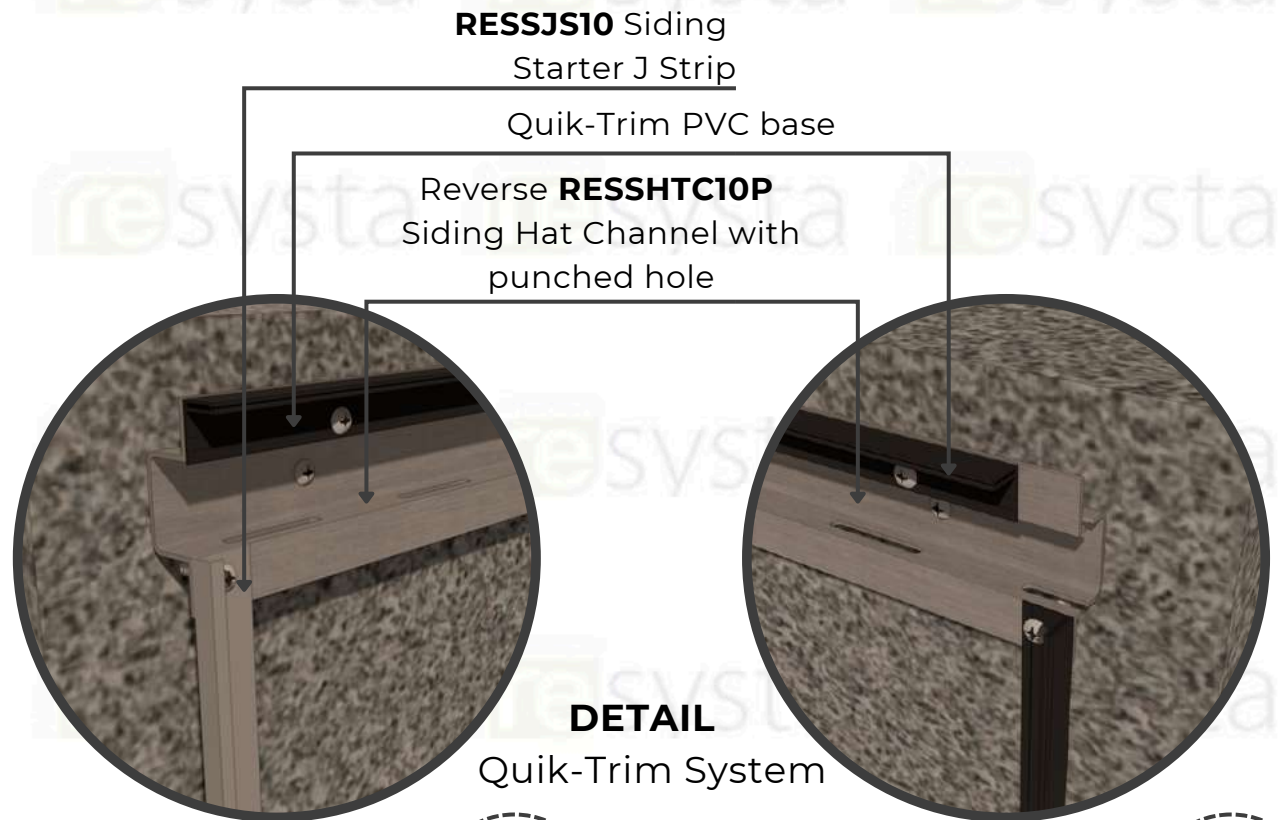

STEP 6.1.3

Follow step 5.4 of Section 5 and install the top rhombus board by butting it against the bottom rhombus board and securing the RESCPSS25 screw into the slotted hole at the bottom of the rhombus board. This screw should be placed at the top of the slotted hole and snug to the rhombus board to allow the board to move freely in the vertical direction allowing for expansion and contraction.



DETAIL A



DETAIL B

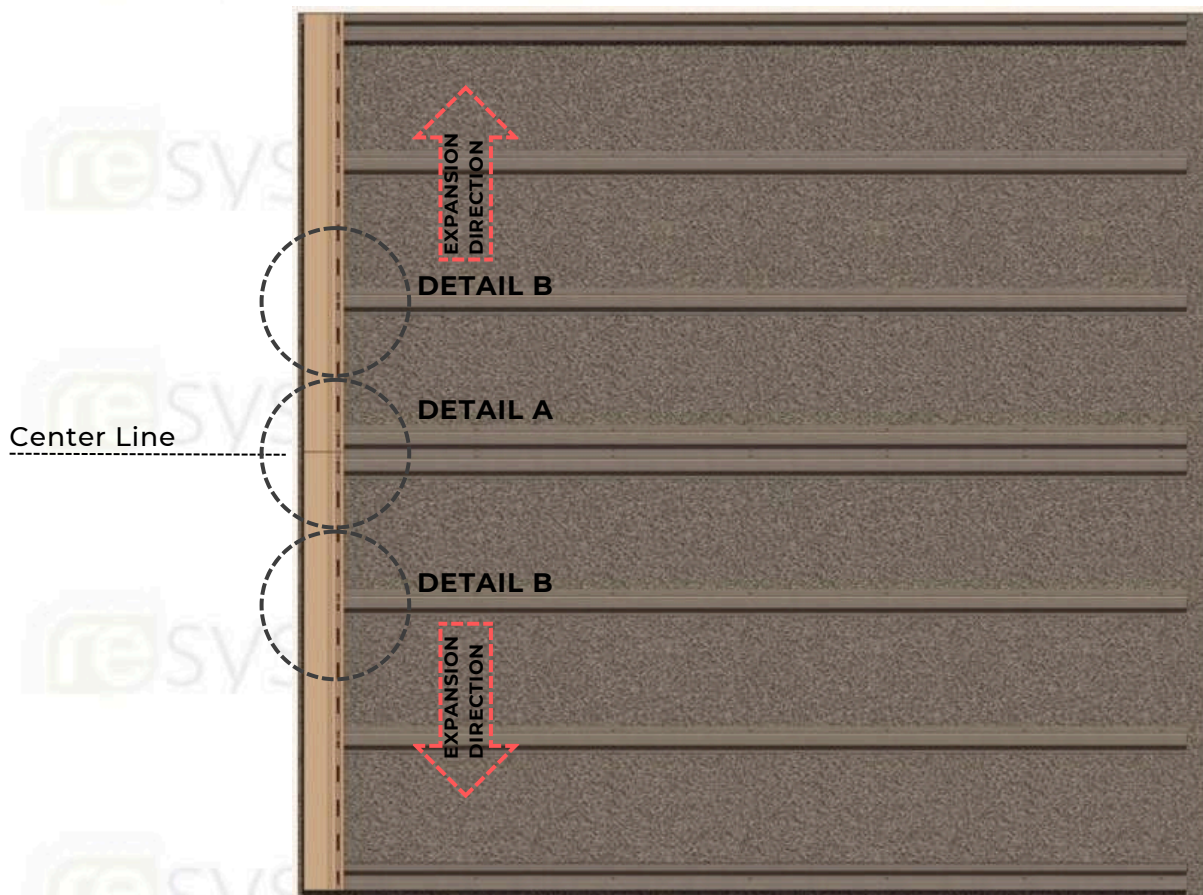

FRONT ELEVATION
Quik-Trim System

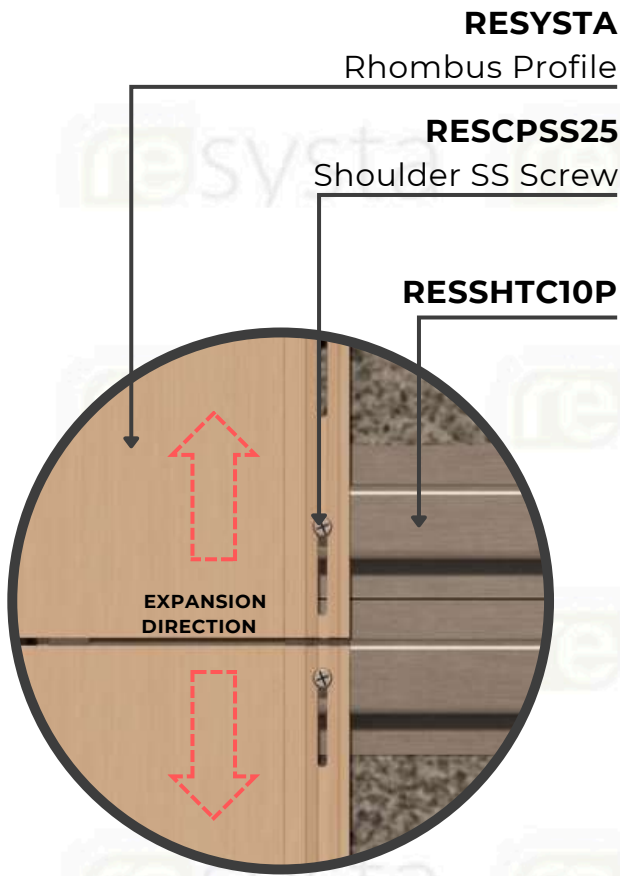

DETAIL A

Hard fasten the screw in the center of the Hat Channel but on the top most part of the Rhombus board slotted

RESSHTC10P Siding Hat Channel with punched hole

RESCPSS25 Shoulder SS Screw

RESYSTA Rhombus Profile



DETAIL B

Loose fasten the screw in the center of the Hat Channel and Rhombus board slotted hole.

STEP 6.1.4

Continuously install the rhombus board vertically and install RESCPSS25 screws into the remaining slotted holes for the top rhombus board. DO NOT over-tighten the screws. These screws should be placed in the center of the slotted hole and loose enough to allow the board to move freely in the vertical direction allowing for expansion and contraction.

RESSHTC10P Siding Hat Channel with punched hole

RESCPSS25 Shoulder SS Screw

RESYSTA Rhombus Profile

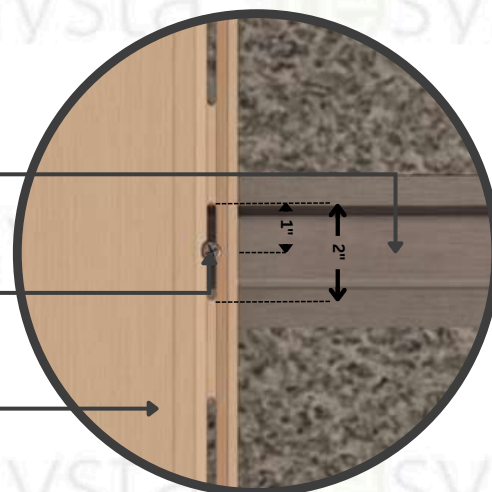

FRONT ELEVATION

Quik-Trim System System

STEP 6.1.5

Hook the groove end of the next board onto the tongue of the installed rhombus board.

Quik-Trim
PVC base

RESCPSS25
Shoulder SS Screw

RESYSTA
Rhombus Profile



DETAIL

Quik-Trim System

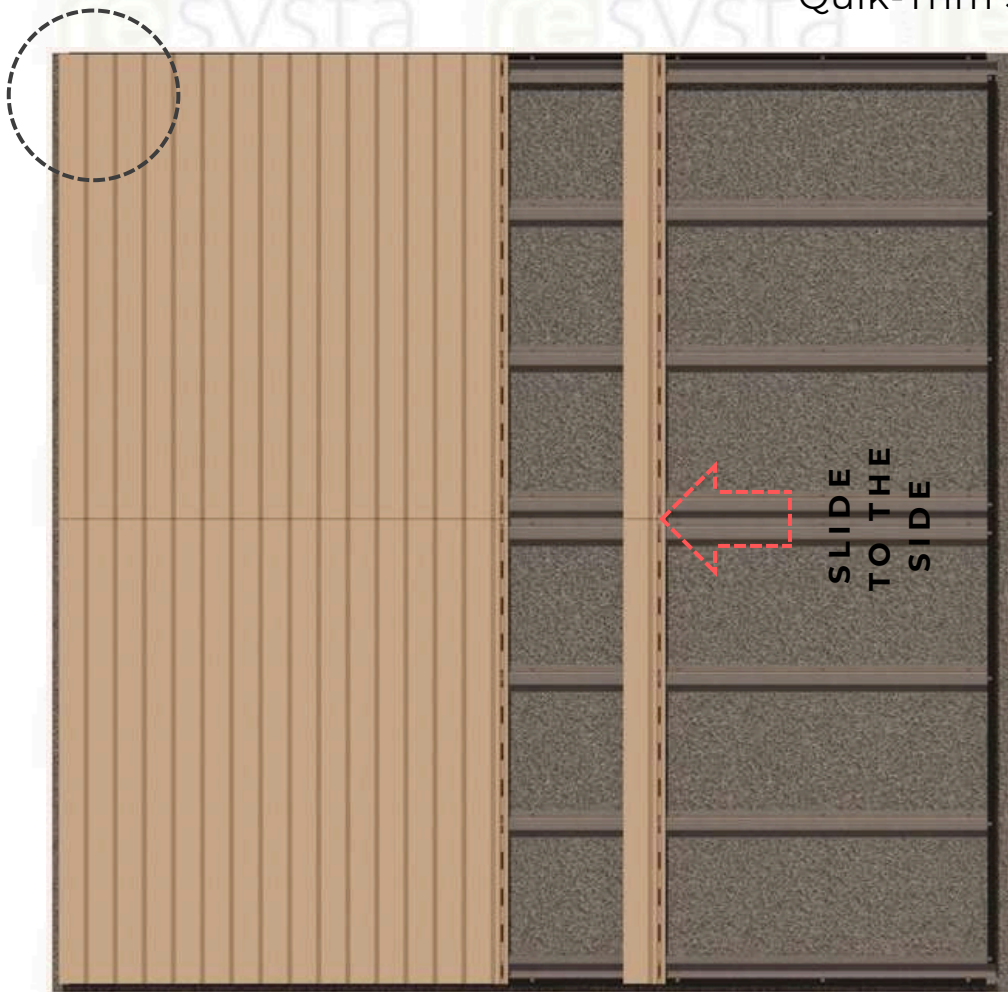

FRONT ELEVATION

Quik-Trim System

STEP 6.1.6

Continue installing the rhombus board vertically as outlined in Section 5 until the last rhombus board is installed.

RESYSTA

Rhombus Profile

Reverse **RESSHTC10P**

Siding Hat Channel with
punched hole

Quik-Trim

PVC base

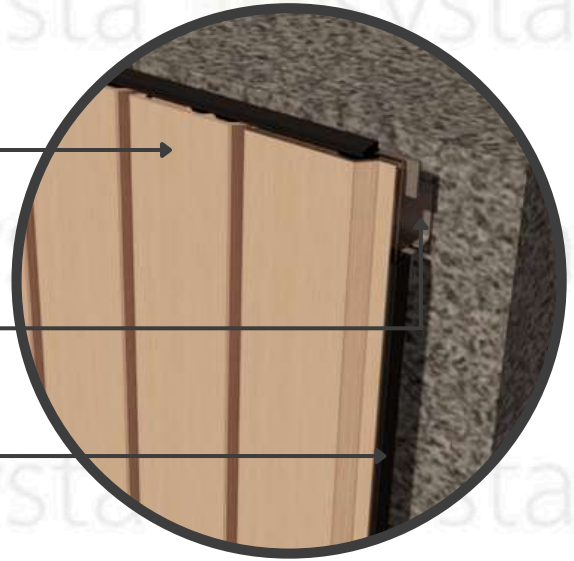

DETAIL

Quik-Trim System

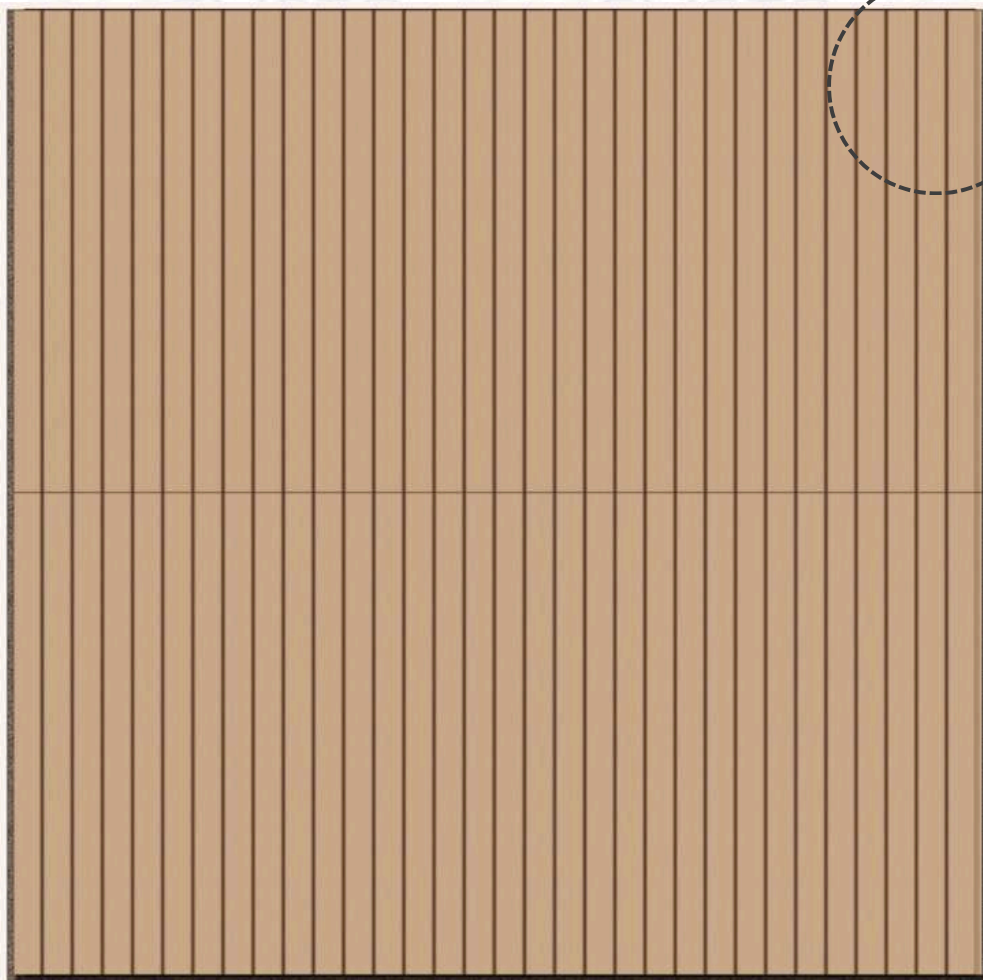

FRONT ELEVATION

Quik-Trim System

STEP 6.1.7

After the installation of the last vertical rhombus board as outlined in Section 6: “2 Board High Installation without the H-Channel Trim”, finally install all the aluminum Quik-Trim on the PVC base to finish the installation.

1/2" GAP

to adjacent surface for
CROSS VENTILATION

RESYSTA

Rhombus Profile

QWJ10

Quik-Trim

Windows J-Mold

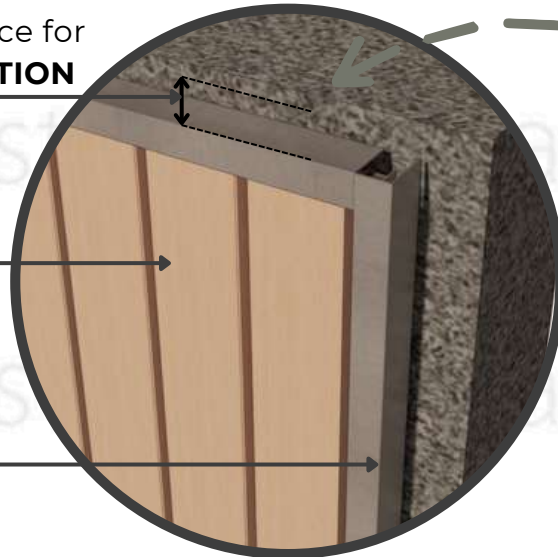

DETAIL
Quik-Trim System

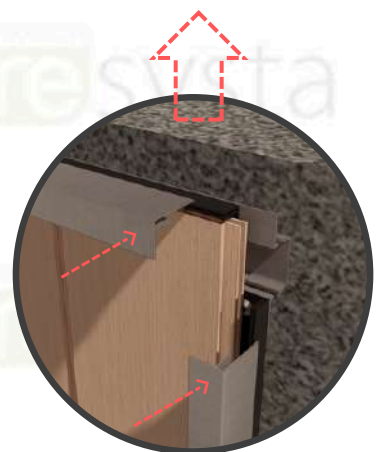
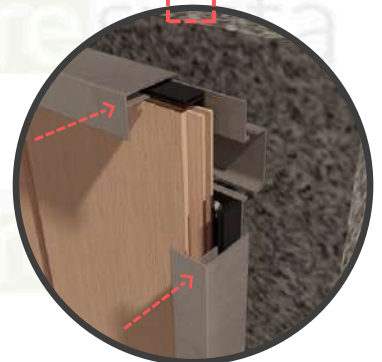

Install the window
J-mold into the PVC
base

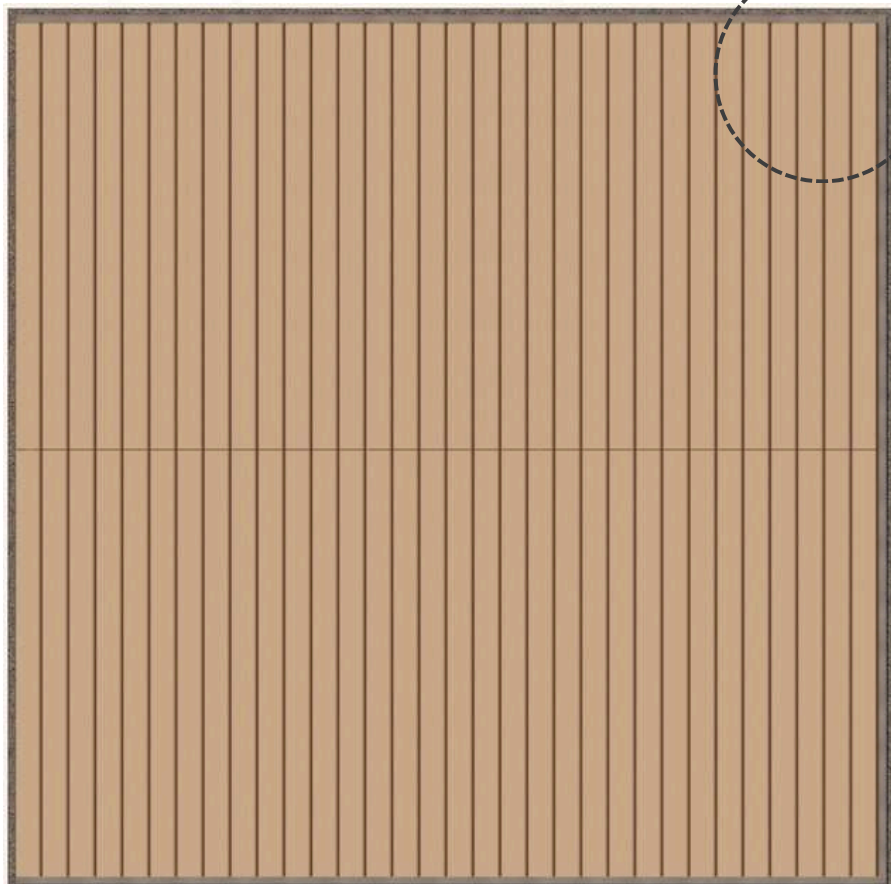

FRONT ELEVATION

Quik-Trim System

Multi-Board Vertical Rhombus Profile High Installation using the Aluminum Quik-Trim H-Mold

STEP 6.2.1

Ensure that two battens have been installed horizontally where boards are to be installed end to end.

STEP 6.2.2

Follow Steps 5.2, 5.3, and 5.4 from Section 5 to install the Quik-trim trim, starter J-strip, and hook in the 1st rhombus board. Install another Quik-trim PVC base horizontally into the hat channel where the H-mold aluminum trim will be installed at each board abutment joint to cover the ends of the Resysta rhombus board. This is an option for installations using 3 or more boards abutted end-to-end. None of the rhombus profile Trim should be installed horizontally unless weep holes are drilled at 8" intervals to allow for moisture to escape from behind the face flange.

STEP 6.2.3

Install the RESCPSS25 screw into the slotted hole at the top of the rhombus board. DO NOT over-tighten this screw. This screw should be placed at the top of the slotted hole and loose enough to allow the board to move freely in the vertical direction allowing for expansion and contraction.

STEP 6.2.4

Hook the groove end of the next rhombus board onto the tongue of the installed rhombus board. Proper gapping between the rhombus board and Quik-trim PVC base for the H-mold aluminum trim finishing.

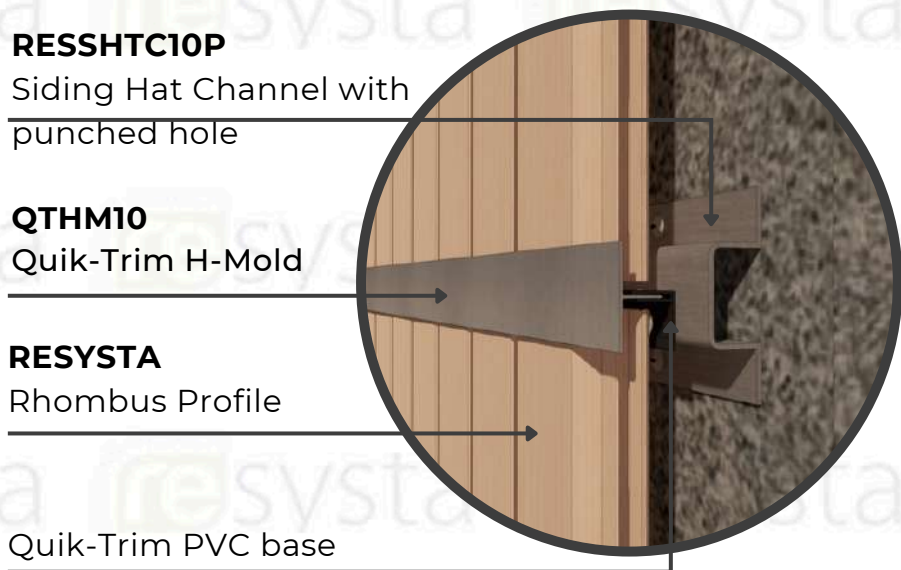

DETAIL

Quik-Trim System

STEP 6.2.5

Continue installing the rhombus board vertically as outlined in Section 5 until the last rhombus board is installed. After the installation of the last rhombus board, finally, install all the aluminum trim on the Quik-Trim PVC base to finish the installation.

Reverse **RESSHTC10P** Siding Hat Channel with punched hole

Quik-Trim PVC base

QWJ10

RESYSTA
Rhombus Profile

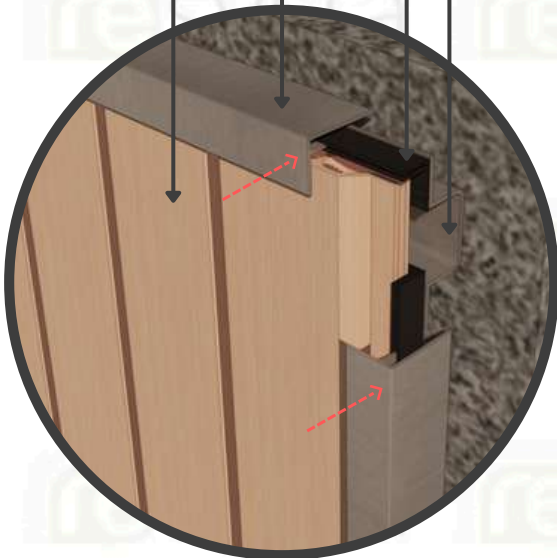

DETAIL A

RESSHTC10P Siding Hat Channel with punched hole

Quik-Trim PVC base

QTHM10

RESYSTA
Rhombus Profile



DETAIL B

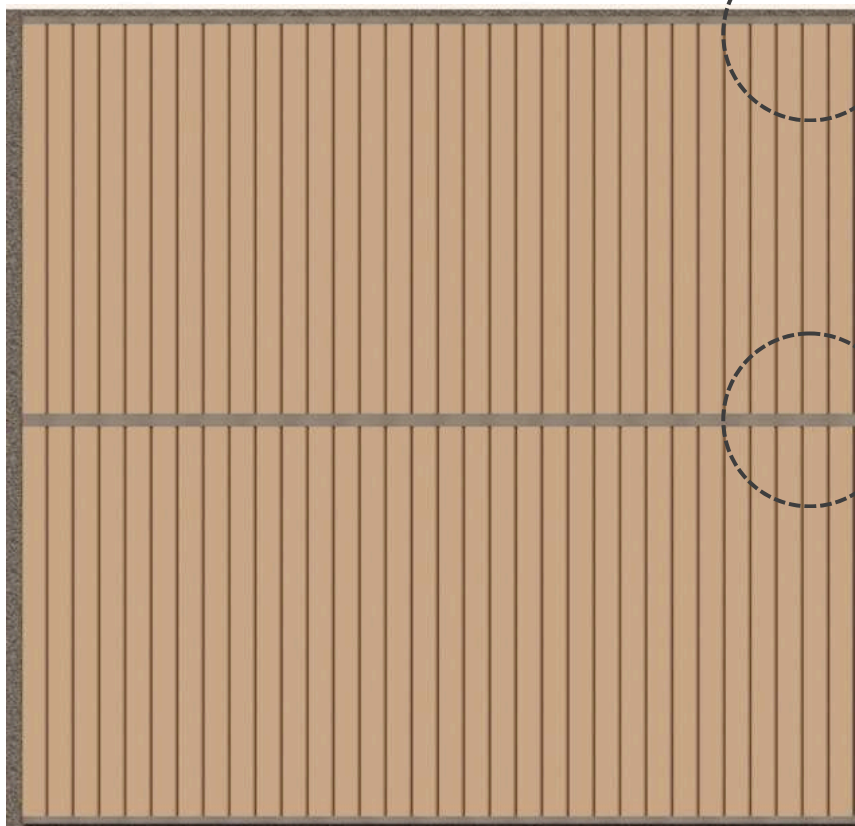

DETAIL A

DETAIL B

FRONT ELEVATION

Quik-Trim System

SECTION 7 – Air Barrier – Requirements

For all of the installation options, it is crucial to allow the uninterrupted flow of air from the bottom to the top of the wall system. This creates a chimney effect which provides not only moisture wicking but also cooling behind the Resysta rhombus board.

Air flow must be able to release at the top of the construction. For that reason a 1/2" gap between the top of the Resysta rhombus board and the Parapet Wall Cap Flashing is necessary. The same size gap is needed between the face of the Resysta rhombus board and the Parapet Wall Cap Flashing. This should also be followed when using the J channel at the top of the wall.

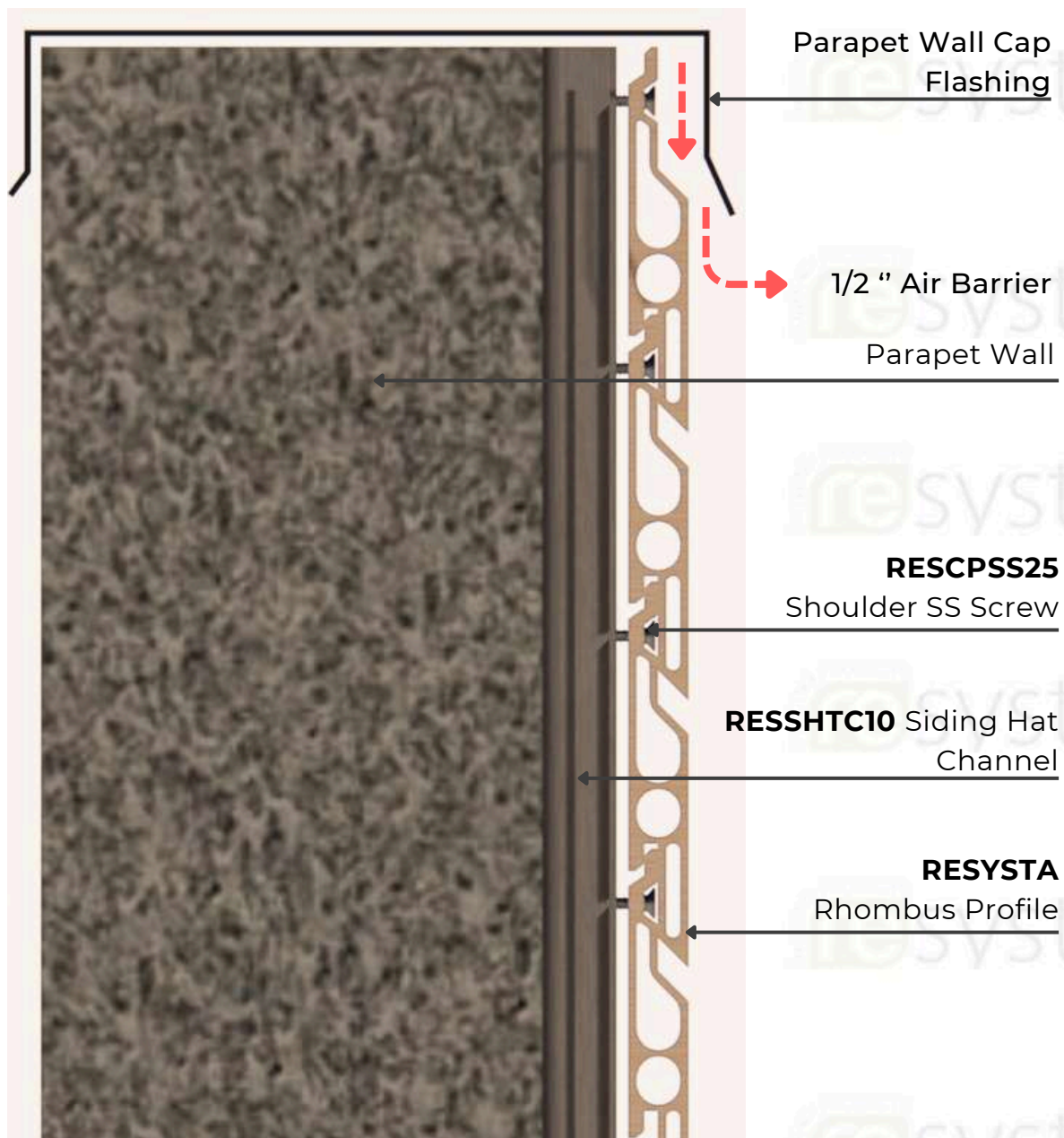

SECTION
Quik-Trim System

SECTION 8 – Quik-Trim Finishing

HORIZONTAL OUTSIDE CORNERS

The Quik-Trim PVC base should be pre-applied prior to installing the rhombus board. The starter J-strip for the first rhombus board should be installed butted against the Quik-Trim PVC base. The rhombus board end should be miter cut at a 45-degree angle to match up with the Quik-Trim PVC base. Follow the gap guide when installing the rhombus board to allow for expansion and contraction on the corners. Install horizontal rhombus per previous sections. When using an aluminum hat channel for an outside corner application, the installer may reverse and attach the hat channel so that the flanges meet. Finally, after the installation of the last rhombus board install the outside corner mold OCM into the Quik-Trim PCV base to finish the outside corner.

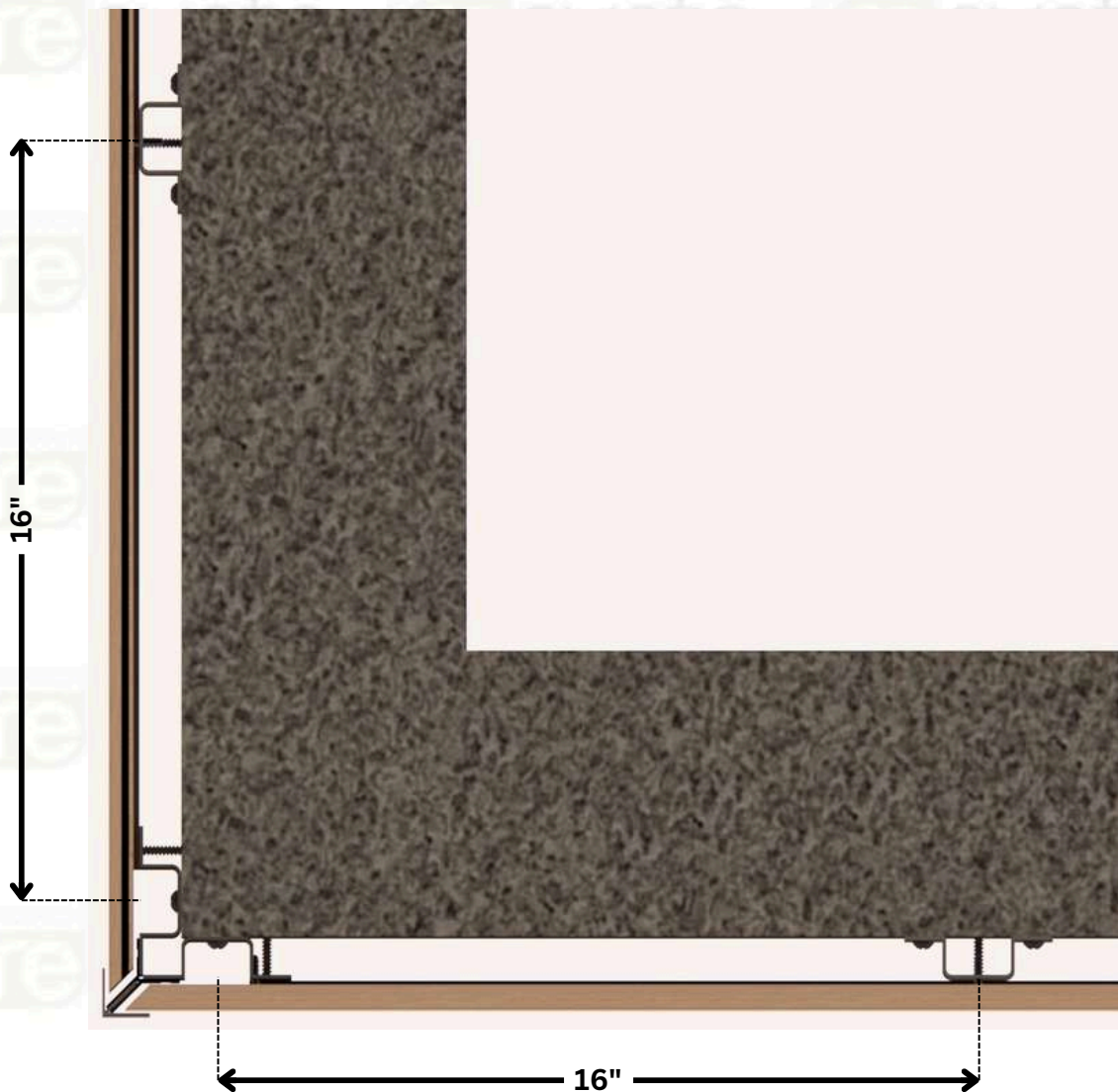

TOP VIEW Outside Corner
Quik-Trim System

Reverse **RESSHTC10** Siding
Hat Channel

Quik-Trim

Outside Corner PVC base

RESYSTA

Rhombus Profile

QTOC10

Quik-Trim Outside Corner

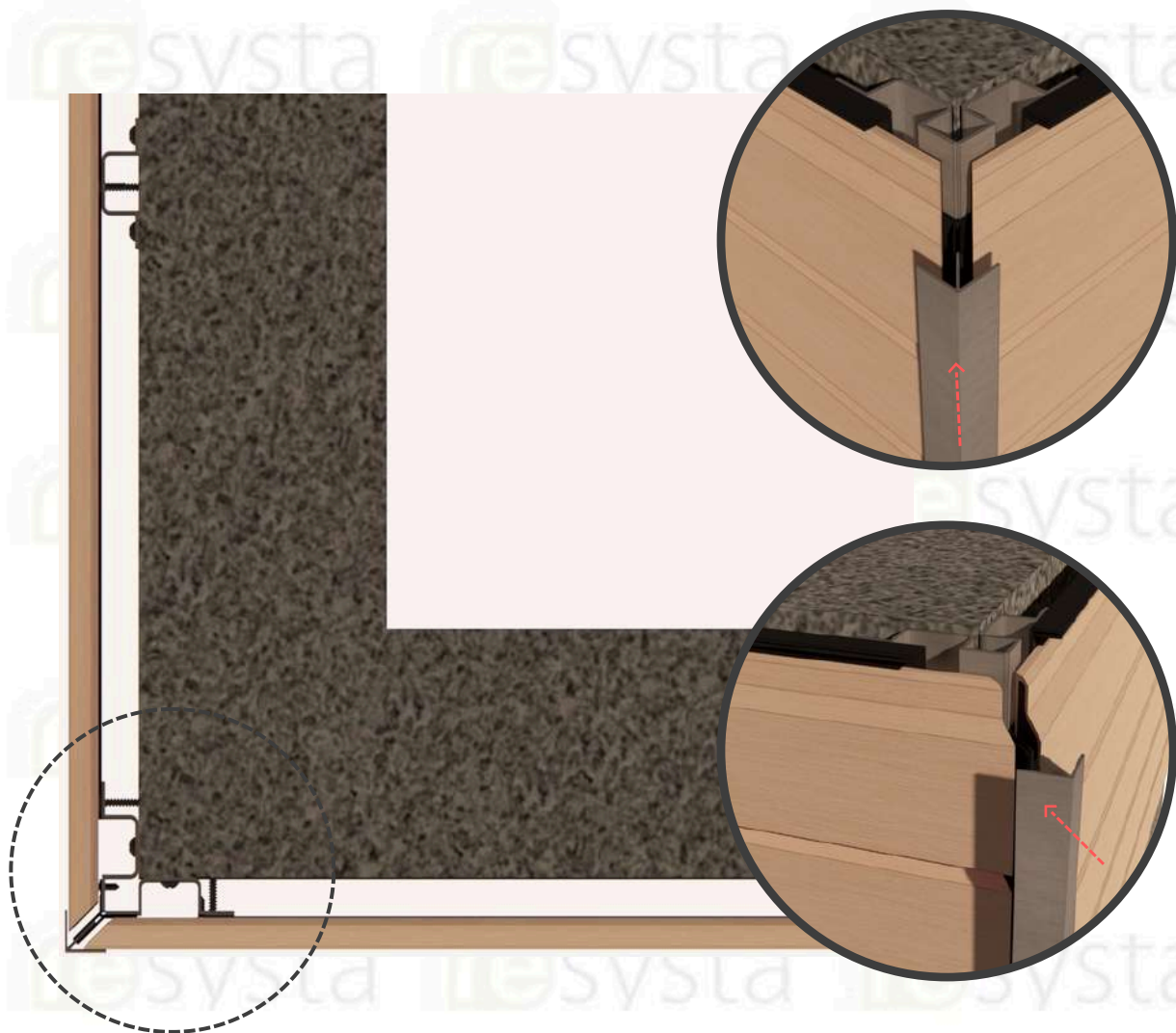
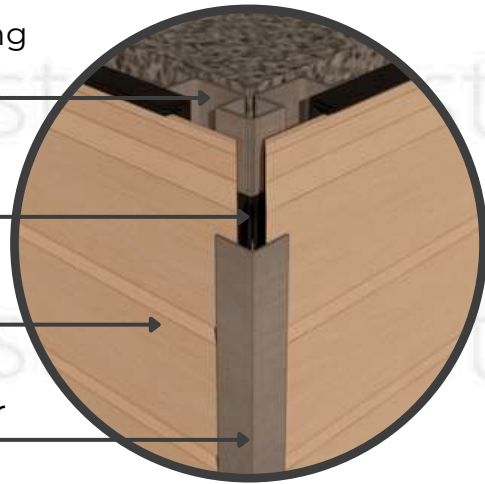

TOP VIEW Outside Corner

Quik-Trim System

To finish the outside corner install the OCM aluminum trim on the outside corner PVC base.

HORIZONTAL INSIDE CORNERS

The Quik-Trim PVC base should be pre-applied prior to installing the rhombus board. The starter J-strip for the first rhombus board should be installed butted against the Quik-Trim PVC base. Follow the gap guide when installing the rhombus board to allow for expansion and contraction on the corners. Install horizontal rhombus board per previous sections. When using an aluminum hat channel for an inside corner application, the installer may reverse and attach the hat channel so that the flanges meet. Finally, after the installation of the last rhombus board install the inside corner mold ICM into the Quik-Trim PCV base to finish the outside corner.

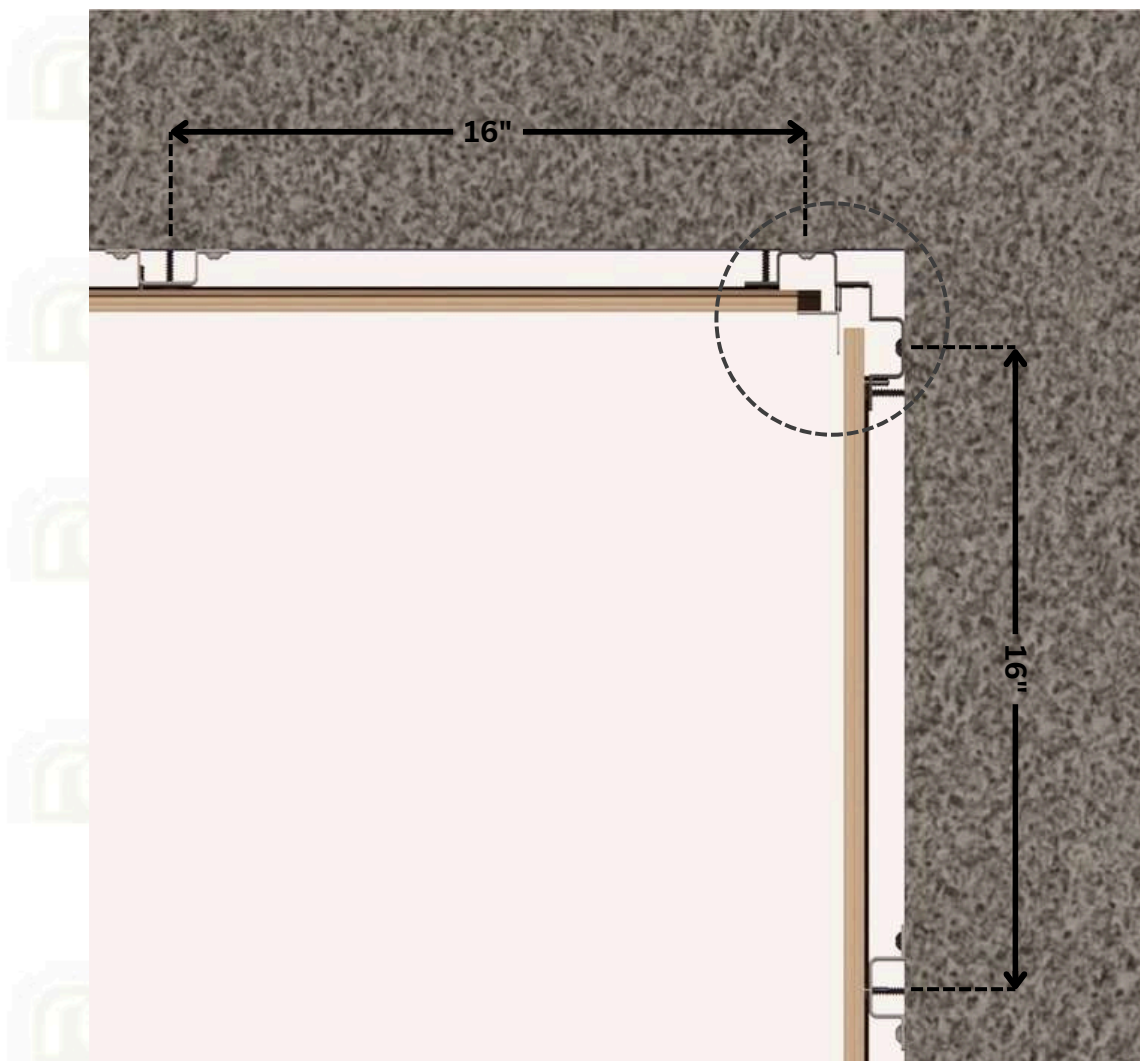

TOP VIEW Inside Corner

Quik-Trim System

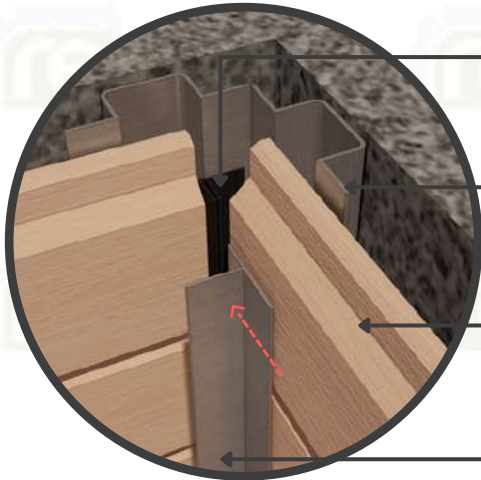
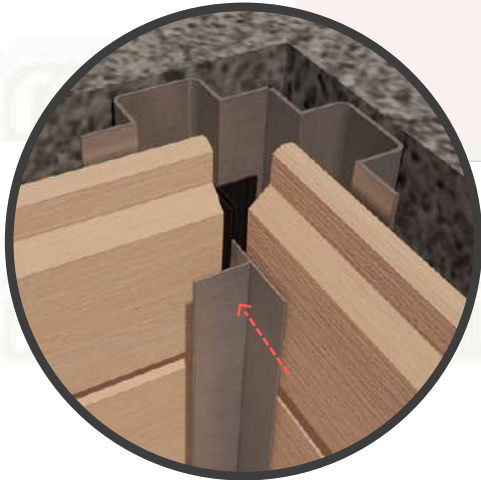
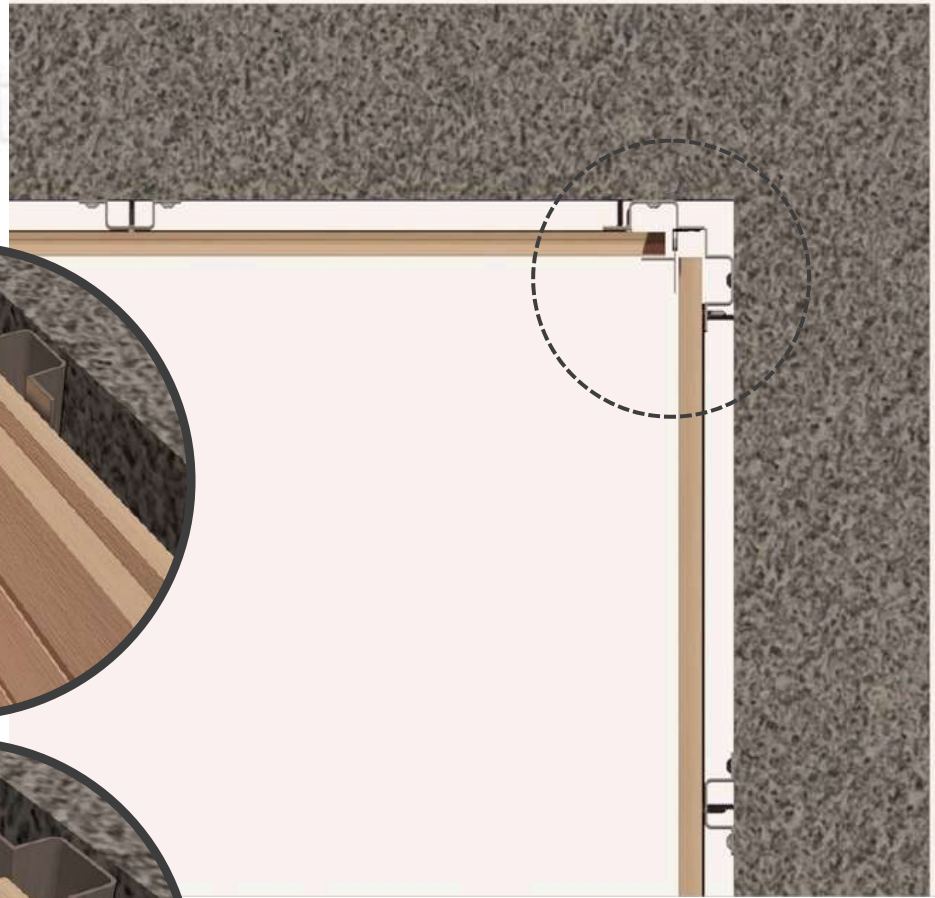

TOP VIEW Inside Corner
Quik-Trim System

Quik-Trim PVC base

Reverse **RESSHTC10**
Siding Hat Channel

RESYSTA
Rhombus Profile

QTIC10
Quik-Trim Inside Corner

To finish the inside corner install the ICM aluminum trim on the inside corner PVC base.

BOARD TERMINATION TRIM

When a rhombus board in either a horizontal or vertical application terminates into a wall, eave, window, door, etc. a Quik-Trim window J-mold should be used to cover the exposed end of the rhombus board. The Quik-Trim window J-mold should also be used along the bottom of a vertical installation. The Quik-Trim PVC base should be pre-applied prior to installing the rhombus board. In the case of an intersecting joint, the starter strip should be installed butted against the Quik-Trim PVC base, not overlapping the Quik-Trim window J-mold trim attachment flange. Follow the gap guide when installing the rhombus board to allow for expansion and contraction within the Quik-Trim window J-mold trim.

HORIZONTAL APPLICATION

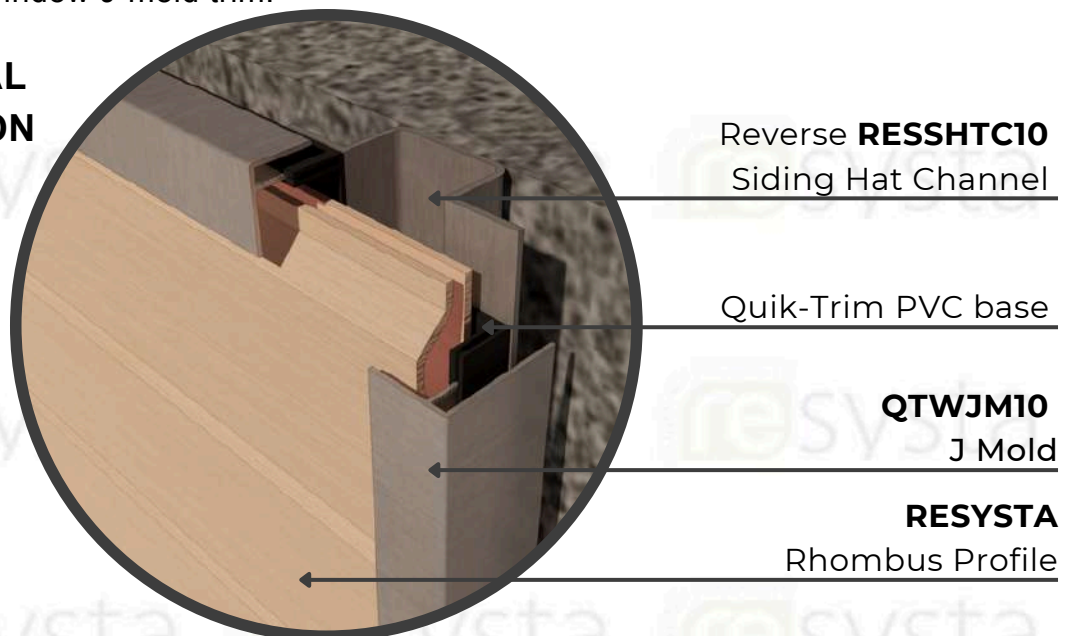

VERTICAL APPLICATION

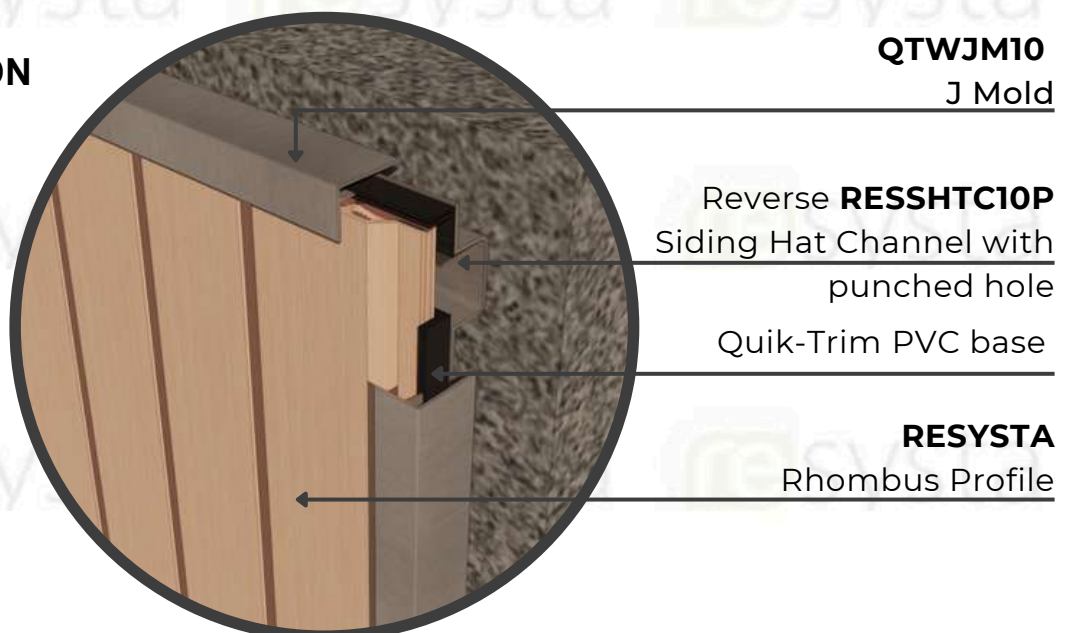

Requirement

When the Quik-Trim window J-mold is installed in a horizontal position weep holes must be drilled at 8" intervals to allow for moisture to escape from behind the face flange. Do not drill weep holes over a door or window installation.

Pinning

is a way to control the direction of expansion of the Resysta Rhombus board, each board needs to be fixed at one end of the board.

Option 01 Every board should hard pin on one end of Resysta Rhombus board to allow one side expansion direction.



Pinning the RESCPSS25 Stainless Steel Screw at the first hole of the Resysta Rhombus board.

Option 02 Every board should hard pin on the middle of the Resysta Rhombus profile to allow for right or left side expansion direction.

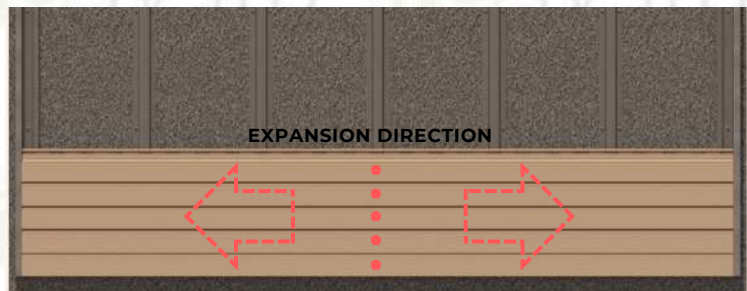

Pinning the RESCPSS25 Stainless Steel Screw at the middle hole of Resysta Rhombus board.

SECTION 9 – Primer and Sealer System

Resysta recommends using an approved water-based primer RBP and stain RCL system.

III. SAFETY WARNING

Resysta® Products do not present an inhalation, ingestion, or contact health hazard unless subjected to operations such as sawing, sanding, or machining which result in the generation of airborne particulate. This product contains amorphous silica. Respirable amorphous silica limits are specified by OSHA. Exposure to respirable (fine) silica dust depends on a variety of factors, including activity rate (e.g. cutting rate), method of handling, ventilation, environmental conditions (e.g. weather conditions, workstation orientation), and engineering control measures used. Exposures to respirable amorphous silica above limits established by OSHA are not expected during the normal use of this product. Amorphous silica has been shown to cause silicosis and has been identified by the State of California, IARC, and NTP as a known human carcinogen. The risk of developing silicosis is dependent upon the exposure intensity and duration. It is recommended that a NIOSH-approved particulate respirator be worn whenever working with this product results in airborne dust exposure.

Please direct product inquiries to:

Resysta North America, Inc.
4035 Cheyenne Ct.
Chino, CA. 91710
Tel: 909-393-2888
Email: info@resystausa.com